



*请注意:由于产品改进,本手册内容可能会与实际购买的产品略有出入。

10072518



在使用缝纫机之前请阅读本使用说明书。
请将本使用说明书放在便于查阅的地方保管。

高速包缝机 B9000系列
HIGH-SPEED OVERLOCK SEWING MACHINE

使用说明书 OPERATION MANUAL 零件手册 PARTS BOOK



手机官网



官方订阅号

浙江中捷缝纫科技有限公司
ZOJE SEWING MACHINE CO.,LTD

地址:浙江省玉环市大麦屿街道兴港东路198号
ADD:DAMAIYU HING KONG ROAD NO.198,YUHUAN,
ZHEJIANG,CHINA

国内营销中心: Domestic Marketing center
TEL:0576-87338345 87338215 FAX:0576-87338222

国际营销中心: Oversea Marketing center
TEL:+86-576-87377013 87378896 FAX:+86-576-87338266
Http://www.zoje.com E-mail:export@zoje.com

浙江中捷缝纫科技有限公司
ZOJE SEWING MACHINE CO.,LTD



为了安全

对于缝纫机本身及各种装置，我们充分考虑到他的安全性。请遵照基本的操作方法，安全的进行工作。

- 拆除为保证安全所设置的装置、零件的情况下使用，是非常危险的，请绝对不要拆除后使用。
- 缝纫机在使用时，请不要在缝纫机台板上放置工具及缝纫时不必要的东西。
- 在对缝纫机进行检修、调节、清扫、穿线、换针等时，为防止发生事故，务必请切断电源。在确定即使踩缝纫机踏板，缝纫机也不动之后，再进行操作。



CAUTION

Observe the safety precautions though takes the utmost care to produce safe sewing machines and devices,operstors should follow these basic safety rules.

- To prevent accidents,do not remove safety devices or parts while operating the machine.
- Do not leave tools or other unnecessary objects on the machine table while operating the machine.
- Before maintenance,adjusting,clearing, threading or replacing the needle,and to prevent accidents,be sure the power is turned dff.Check that the machine will not operate when the pedal is pressed.

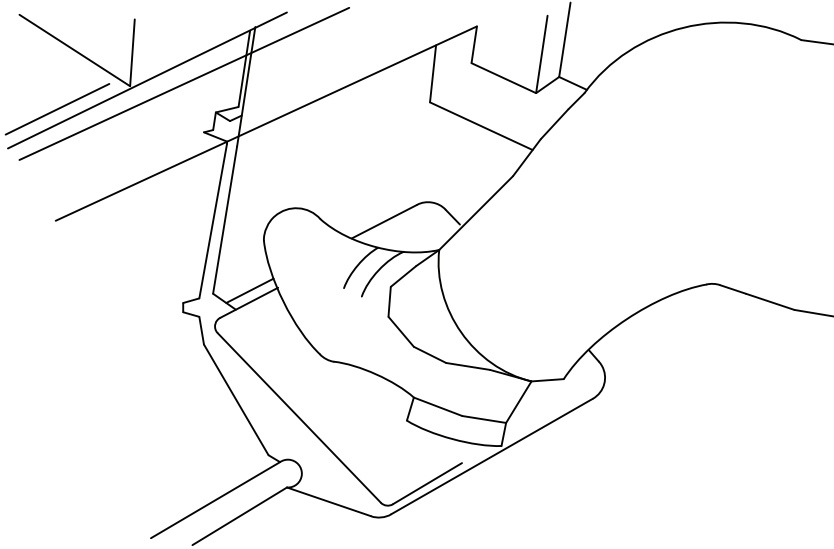

- 在离开缝纫机台时，请务必关掉电源。
- 停电时也请务必关掉电源。
- 为了总是安全地、运转良好的使用缝纫机，经常的检查是不可缺少的。请予以注意。
- Turn the power off before leaving the machine table.
- In the event of a power failure,be sure to turn the machine off.
- Check that the machine is securely grounded.

台板加工图

Schematic diagram of the machine table

请参照下图进行台板的加工

Cut the table referring to the diagram

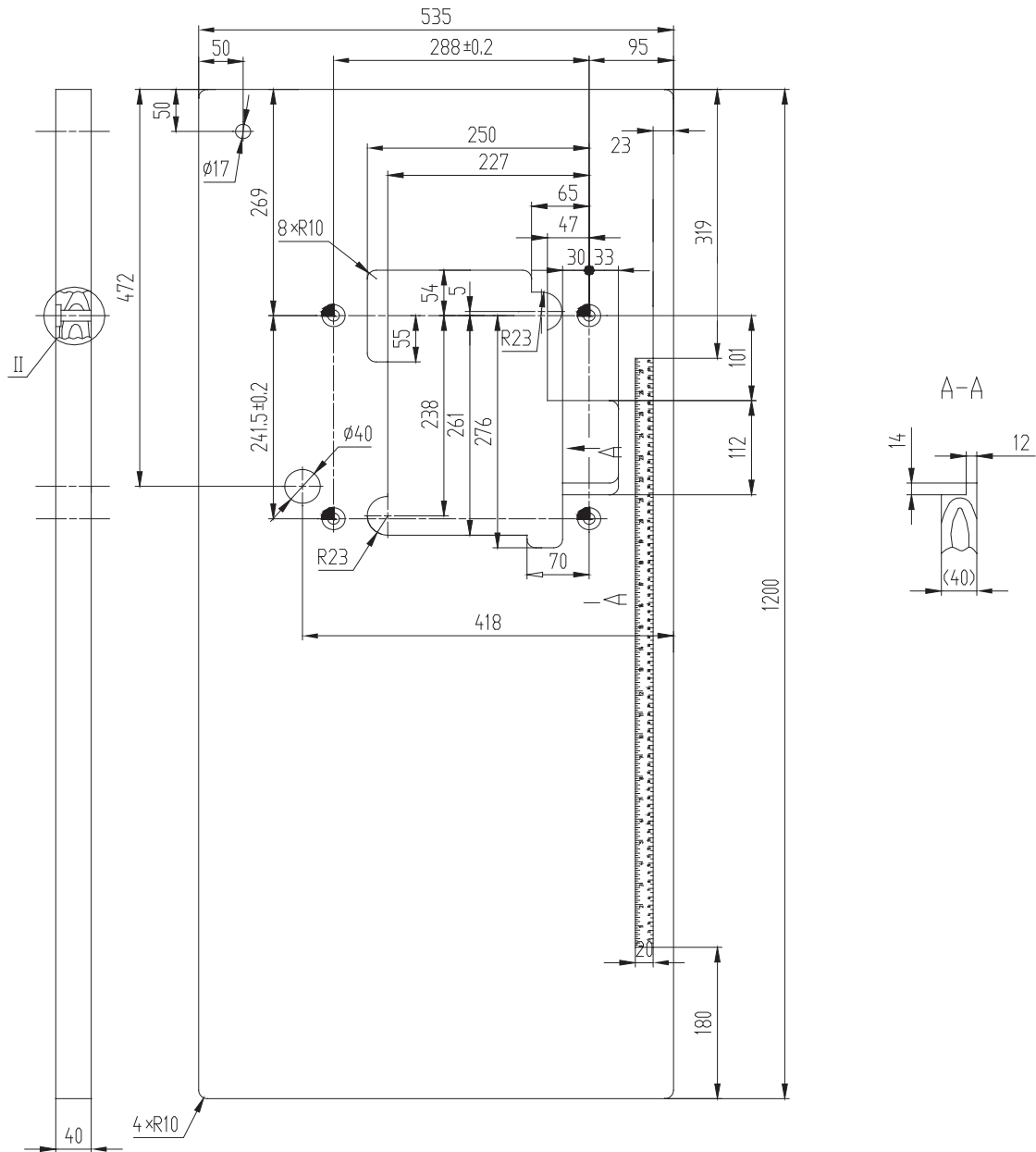

标准尺寸
Standard dimension

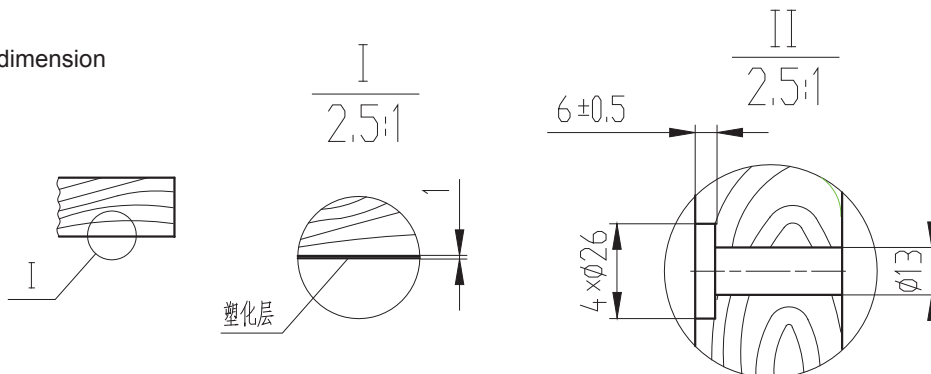

加润滑油 Lubrication

加油量是使油面处于H线与L线之间为好。
当油量低于L线时，就要及时补充机油。

After filling the oil , the top of the indicator
should lie between (H)and(L) lines.

Add oil,when the oil level indicator reaches or
goes below(L).

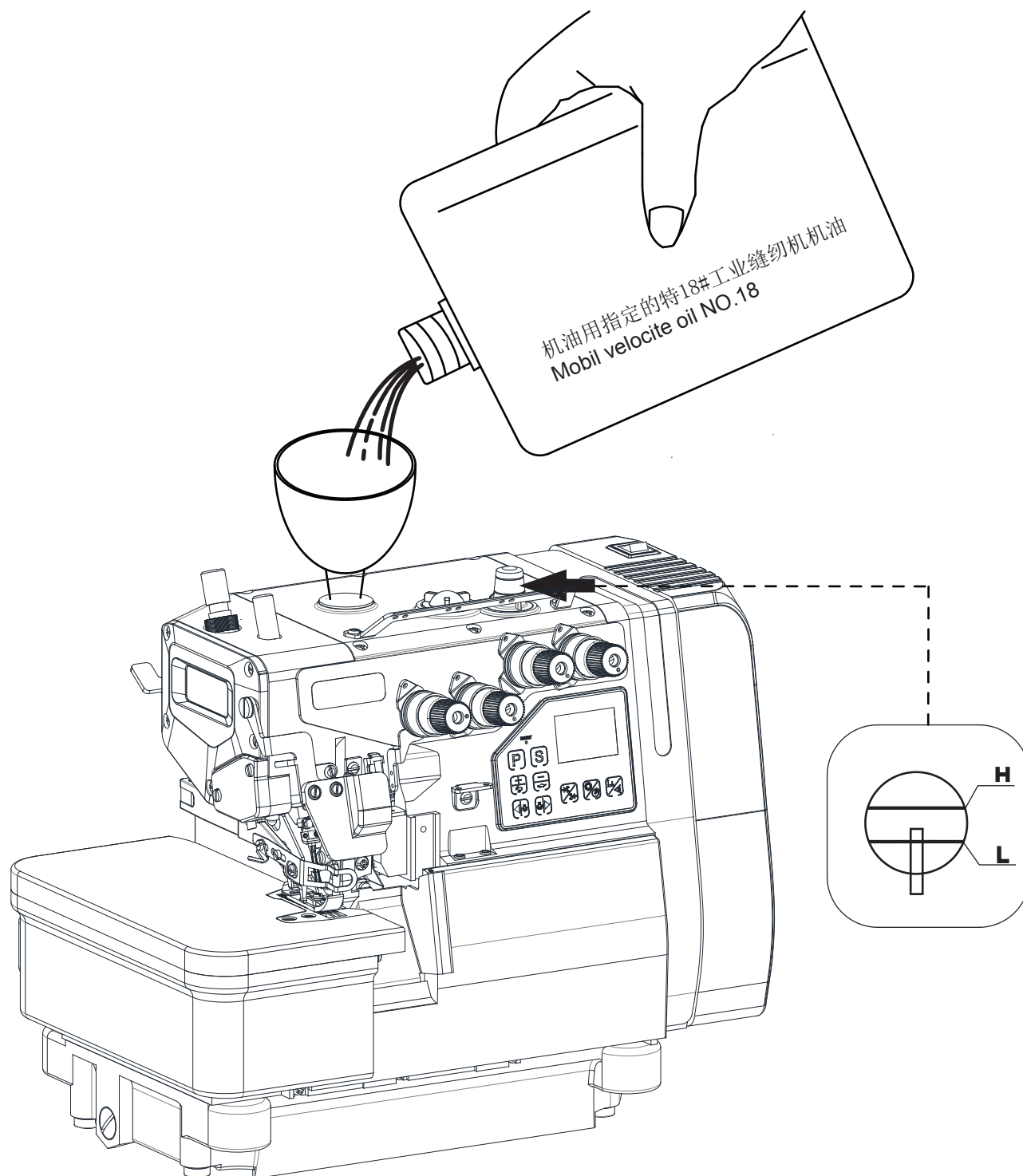

手动给油 Manual Lubrication

手动给油是在缝纫机最初开始使用时。
或相当一段时间没使用了时，请供给
2-3滴油。

Apply 2 or 3 drops of oil by hand when the
machine is used for the first time or has
been left unused for some time.



机油用特18#工业缝纫机油
Mobil velcite oil NO.18

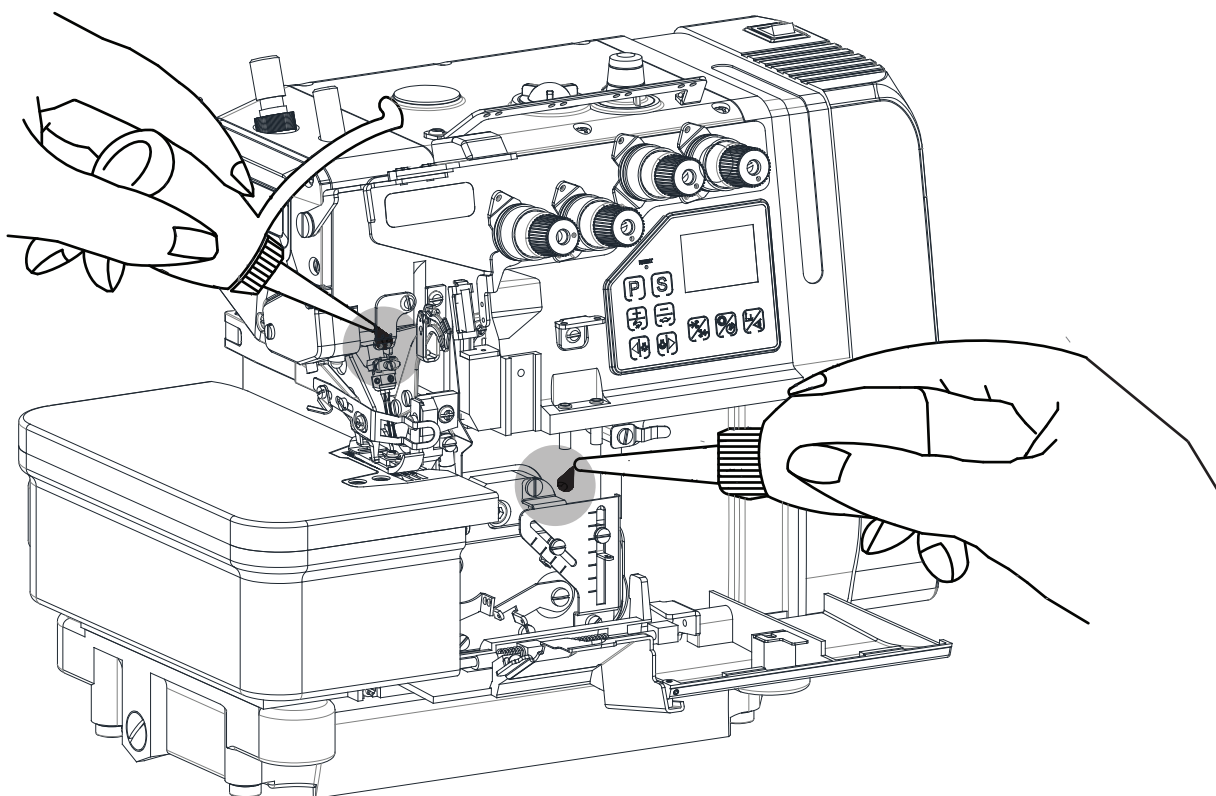

给HR装置供油 Filling the HR device with silicon oil

为了防止断线，尽早给HR装置供油。
注：关于购买硅油，请咨询代理店或公司
营业部联系。

Fill the HR device oil before it is too low in order
to prevent needle thread breakage and fabric
damage.

Note: Use Zoje recommended silicon oil.
[UNION CARBIDE CORPORATION]
UCC L-45(10)

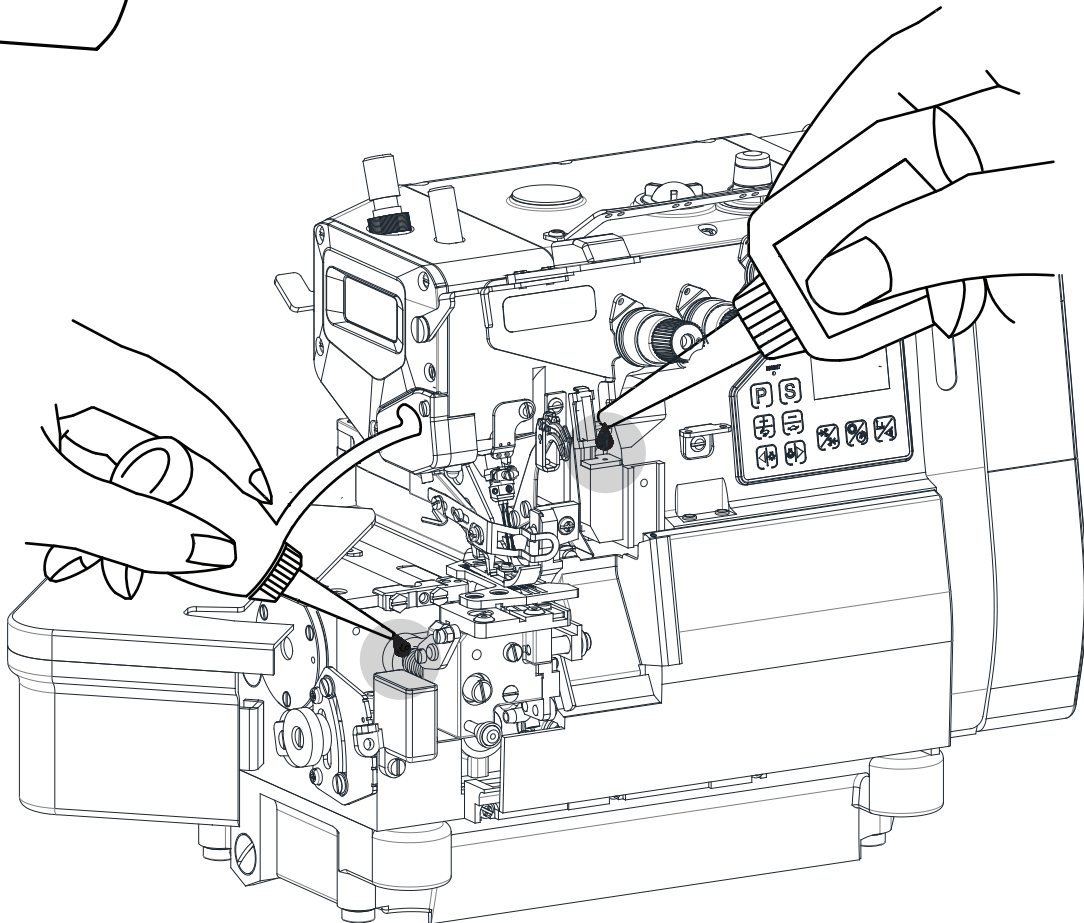

穿线的方法 Threading

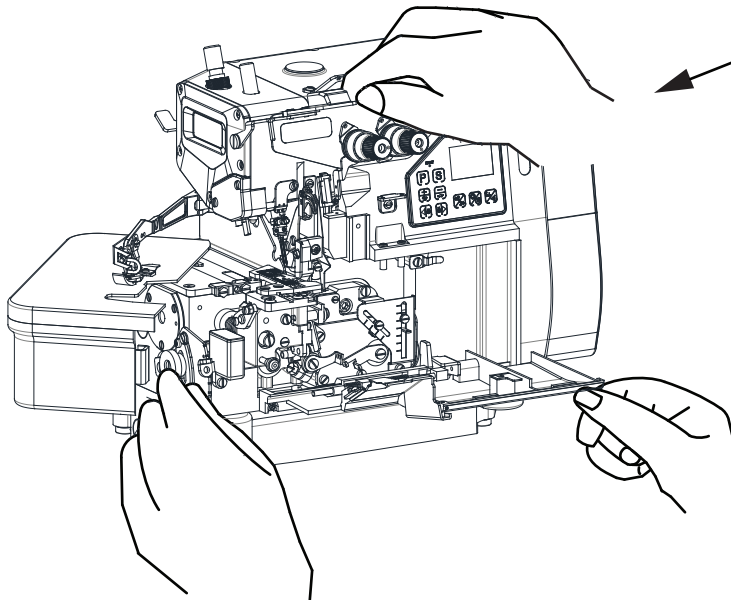

① 打开防护罩、大盖及前盖，再移开压脚
Open three covers and remove the
presser foot aside.

把机器上原有的线与缝纫
用线绑结在一起。
② Knot the preset thread and the
thread being used together to
thread the machine.

针线
Needle thread

将线拉到针眼前，剪掉
结头再次穿好针线。
Trim the knots off neatly
before passing through
the eye of the needle to
rethread

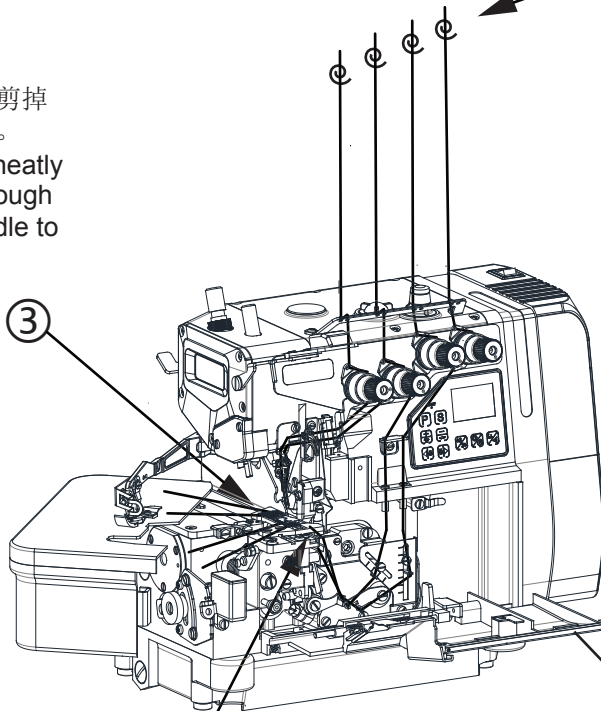

若机上原来没有线，请参照穿线
图正确进行穿线。

threaded correctly by referring
to the threading diagram.

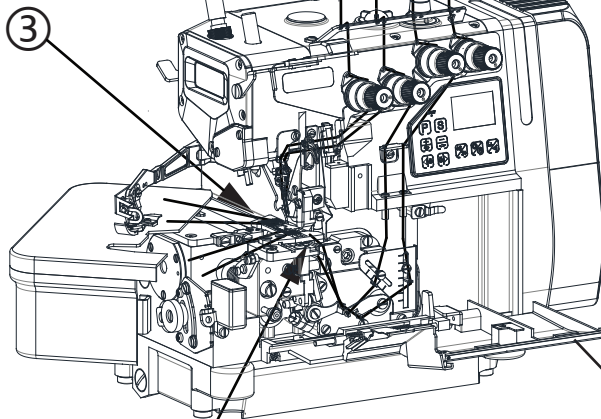

穿线图
Threading diagram

弯针线
Looper thread

线拉出接头后，用剪刀齐接头。
Trim the knots off neatly
after passing through the
eye of the looper.



压脚压力的调节 Adjusting the presser foot pressure

压脚压力的调节，松动螺母①，调节螺母②，在送布得到稳定状态下尽可能使用较弱的压力为好。

Loosen adjusting nut ① and turn adjusting nut ② to adjust the presser foot pressure. It should be as light as possible. Yet be sufficient to obtain the proper stitch formation.

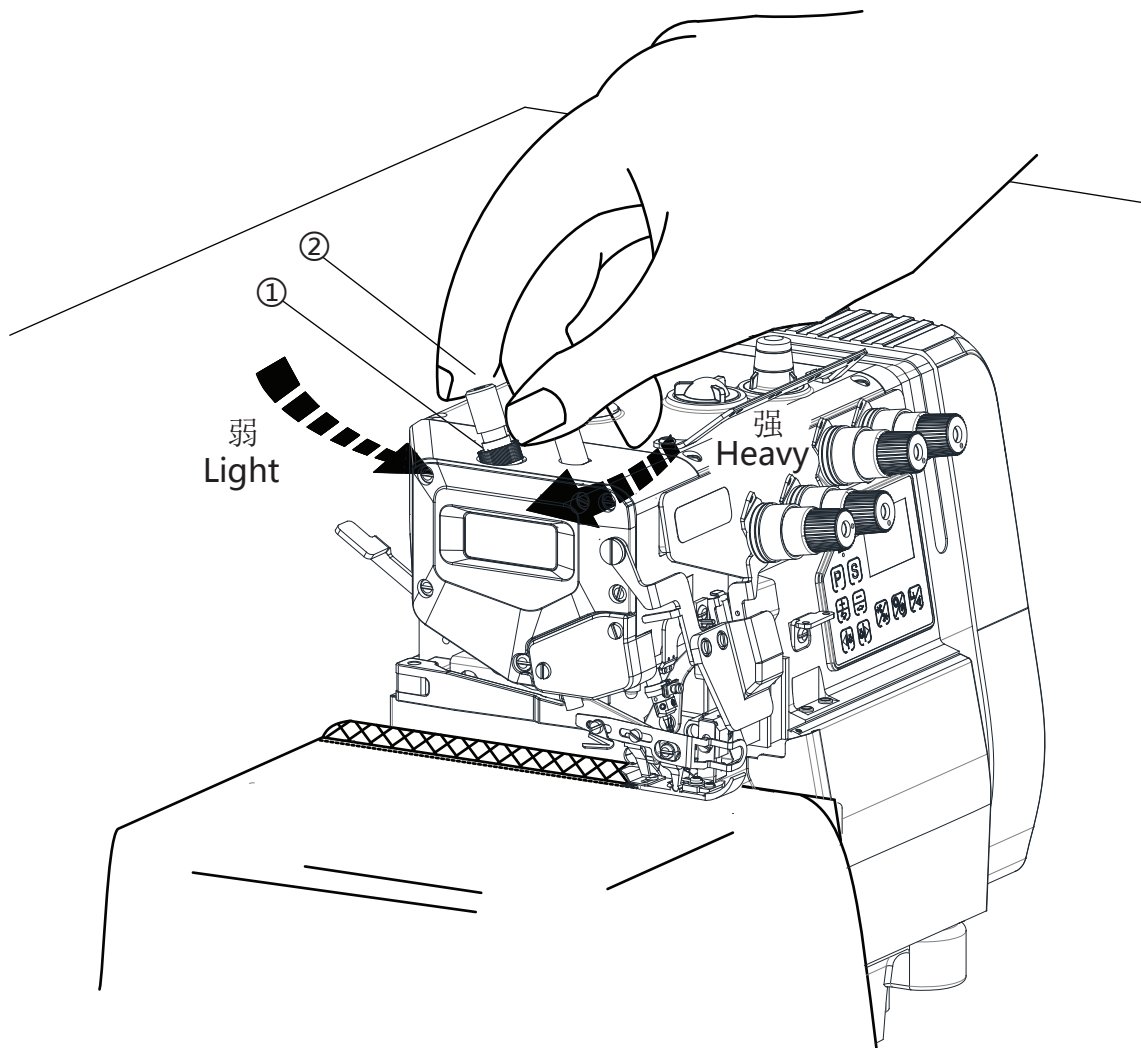

差动比的调节 Adjusting the diff. feed ratio

差动比的调节
松开螺母①，然后调节差动调节杆②。

Loosen the nut ① and turn the adjusting rod ② to adjust the differential feed ratio .

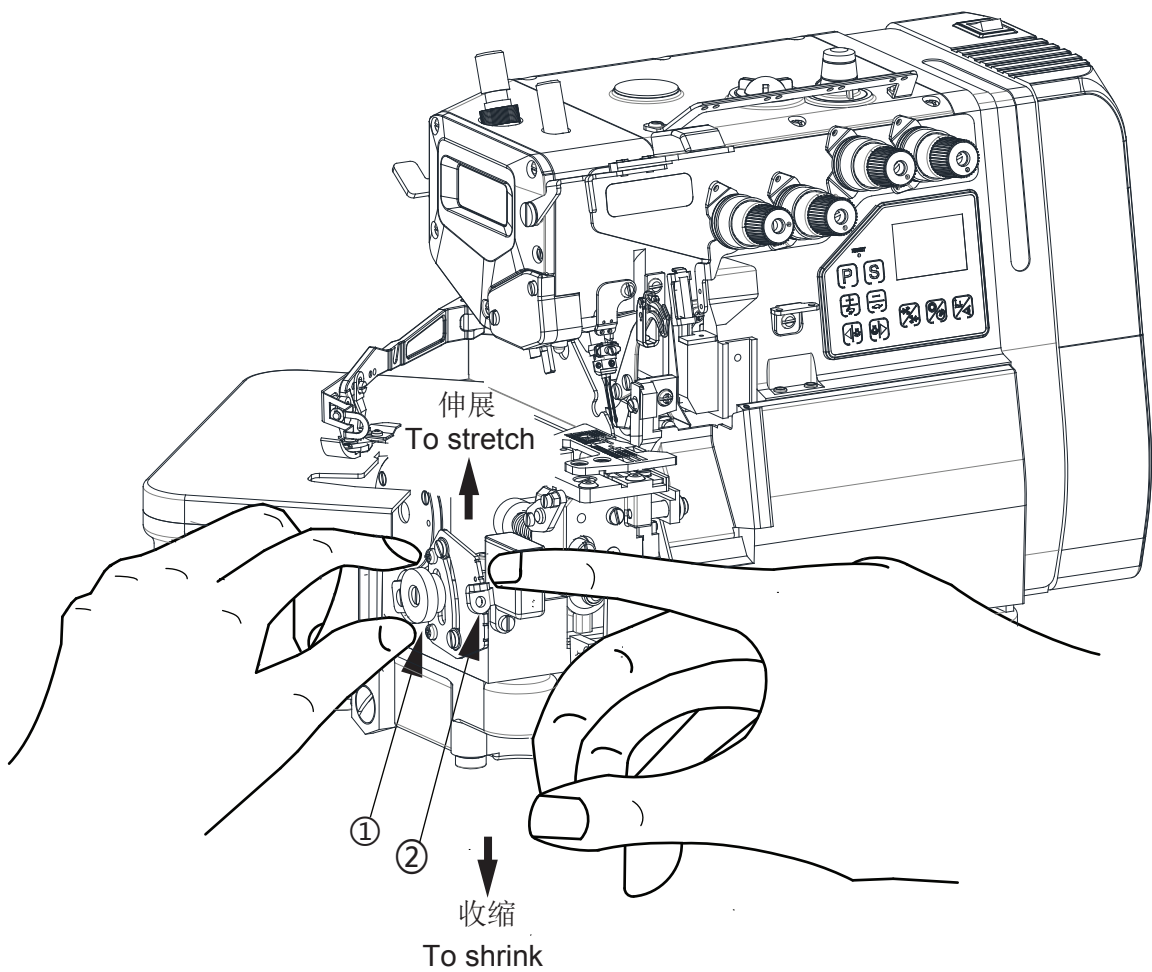

针脚长度的调节 Adjusting the stitch length

1. 摁住按钮，旋转手轮，按钮会陷进更深处。 ① While pressing the push button, turn the handwheel to seek the position at which the push button goes further into the depth.
2. 这时边摁住按钮，边转动手轮，使校准标记号对准所希望的数值。 ② Then, keeping the push button pressed, turn the handwheel and set the desired scale to the aligning mark.

注：针脚长度的调节务必请在调节差动比之后进行。

Note: Stitch length adjustment must only be made after the differential feed ratio has been changed.

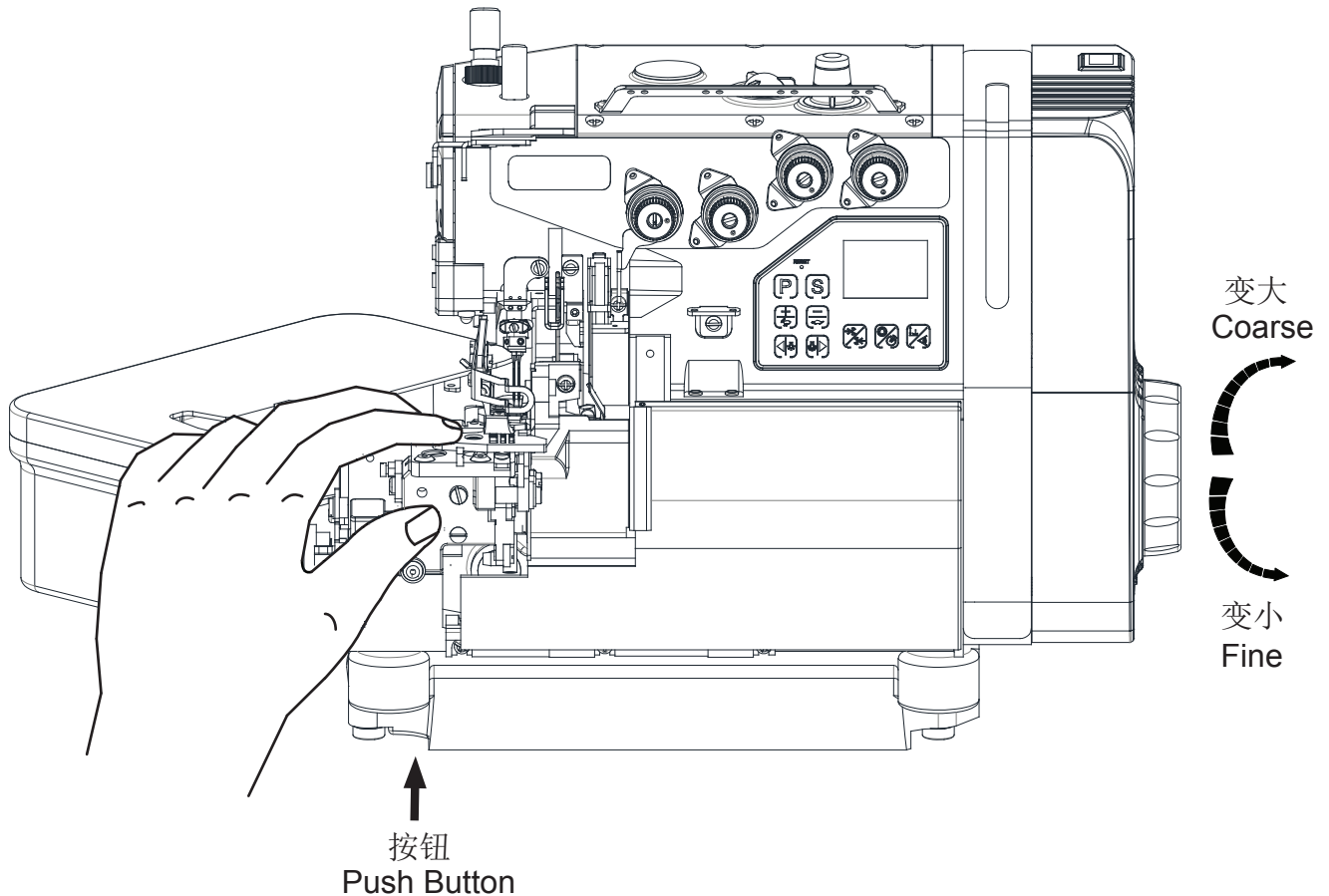

线张力的调节 Adujsting the thread tension

线张力状态的调节，请用针线调节螺帽①、上弯针线调节螺帽②、弯针线调节螺帽③来进行调节。

Make tension adjustments with the needle thread knob①、the upper looper knob②、and the lower looper knob③.

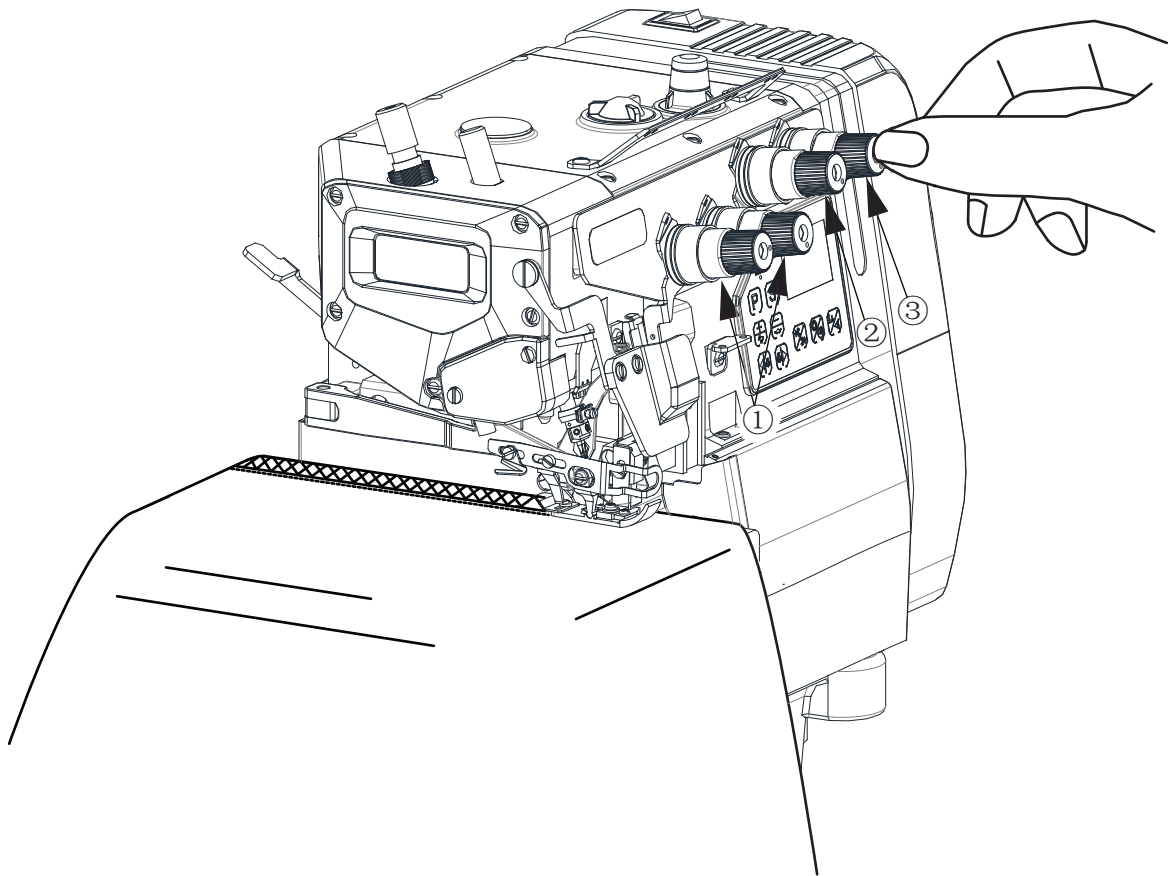
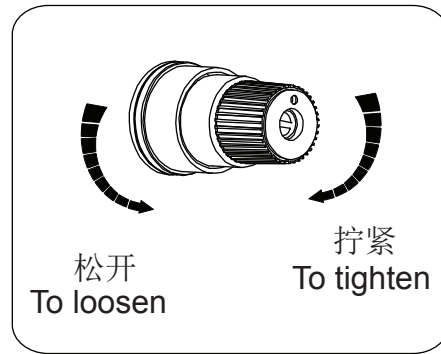

清洁缝纫机 Cleaning the machine

缝纫机的清扫，以针板槽及送布牙周围为主。

Mainly the slots of the needle plate and the feed rows should be cleaned

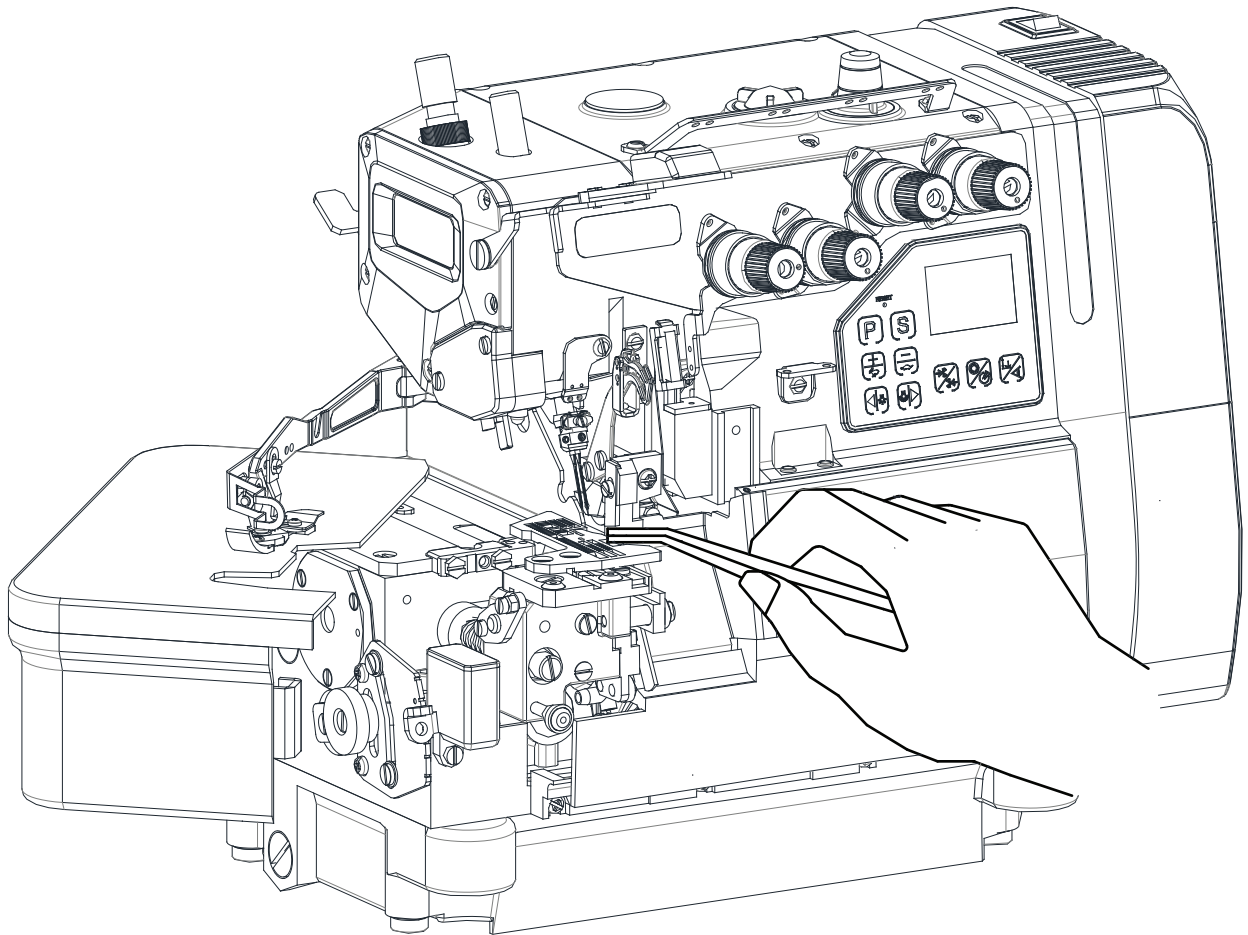

换机针

Replacing the needle

准确辨认针的前后，请将针凹向着后方，
即背向操作者进行安装。
针要牢固的插到孔的最深处。

- * Check the needle carefully to see that the scarf is turded to the rear of the machine.
- * Insert the needle to the proper depth, and fasten securely.

标准使用针：DC×27
Standard needle: DC×27

OK! NO!

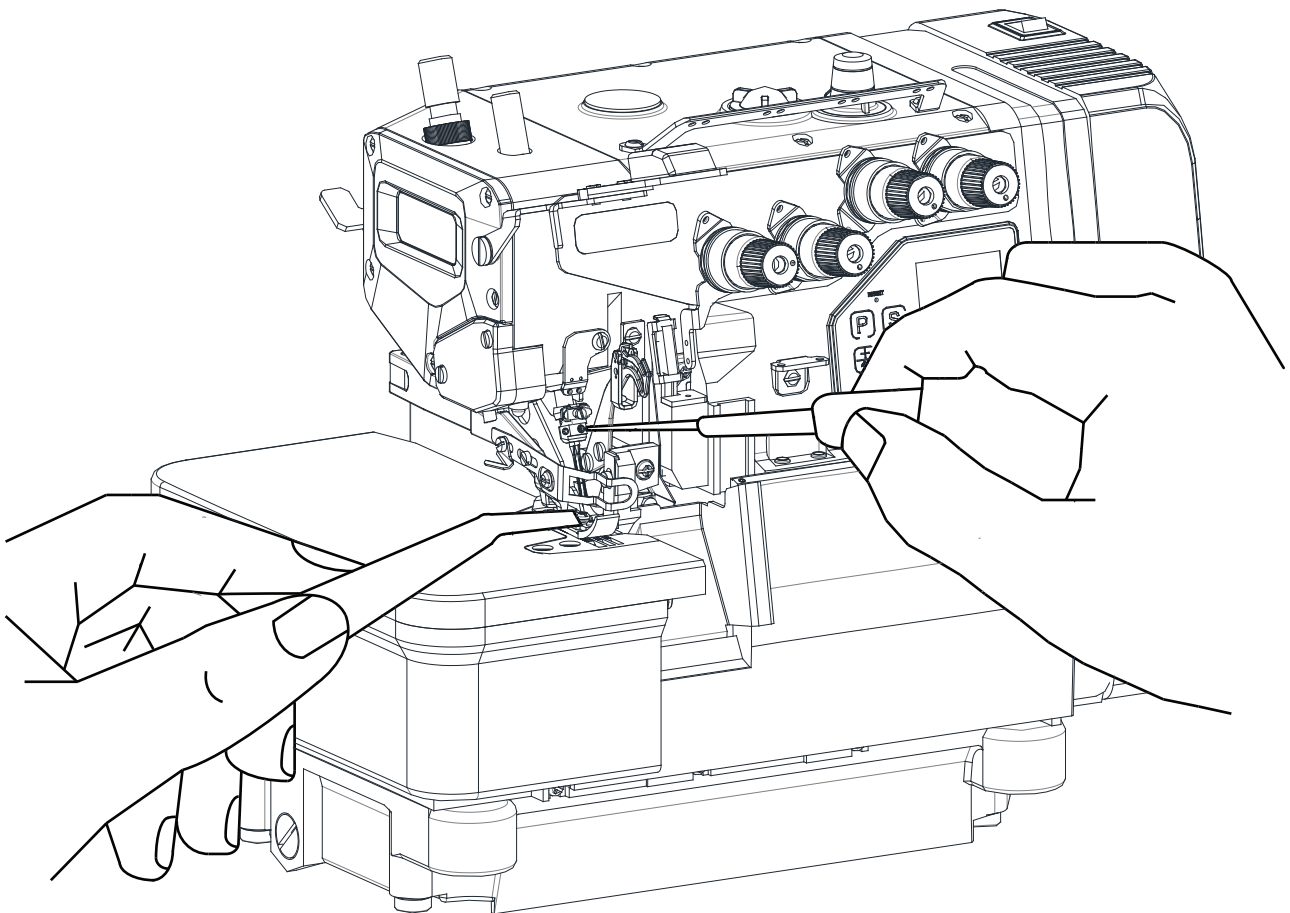
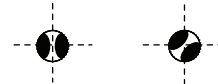
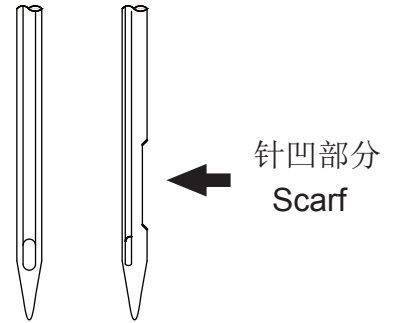

检查机油的循环
Checking the oil circulation

OK! 运转中
(Operating)

↓

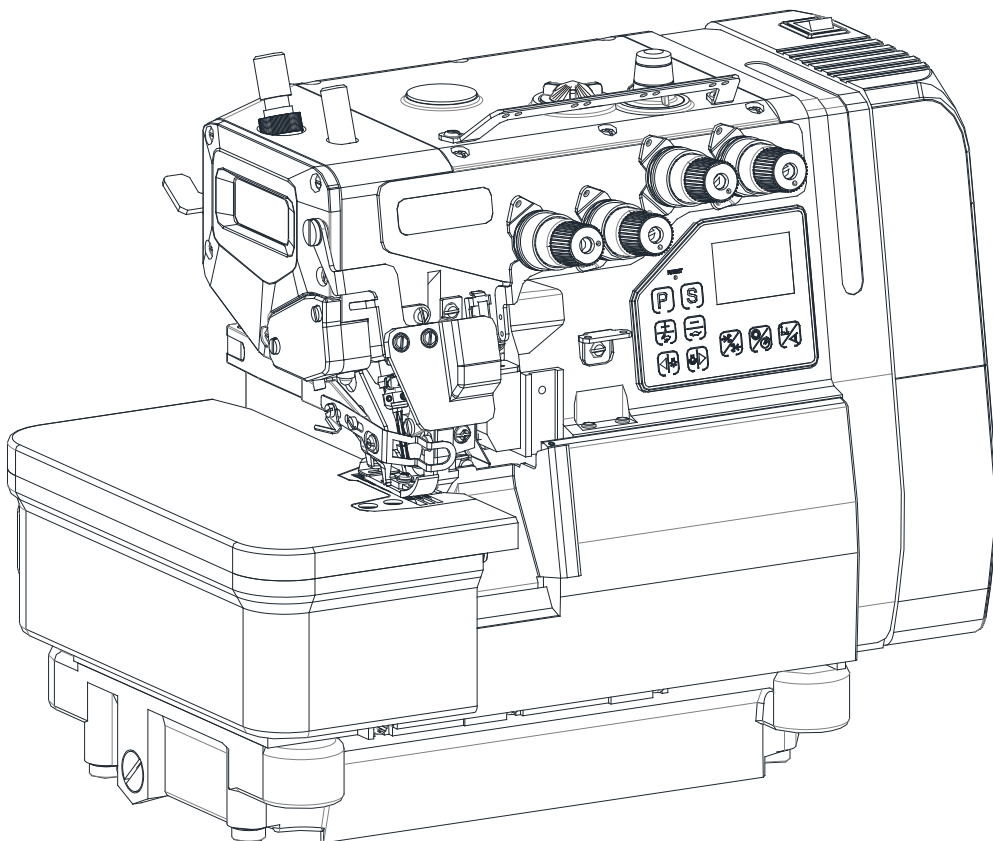

检查和更换滤油器 Checking and replacing the oil filter

滤油器每6个月检查并更换。

Check and replace the oil filter every six months.

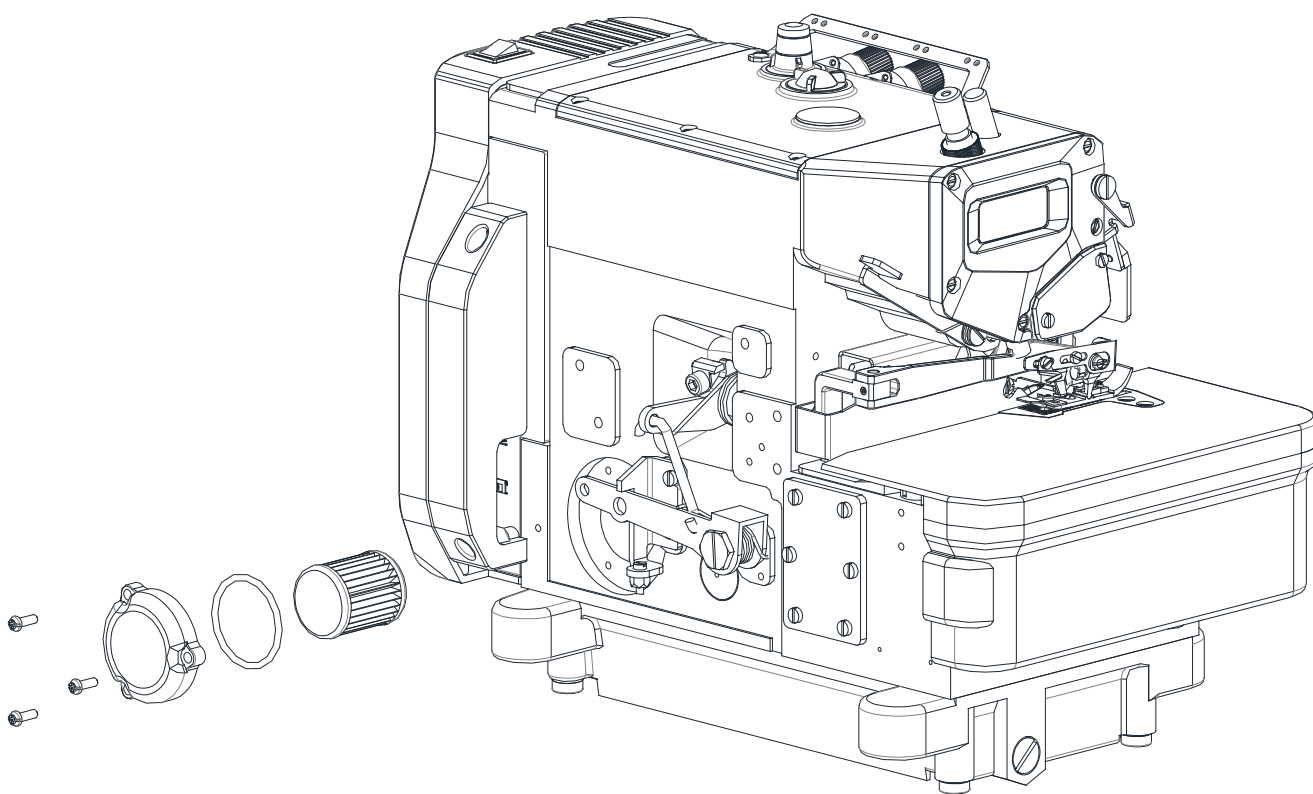

换机油 Replacing the oil

机油的更换，请在使用开始1个月后更换一次。然后，每6个月更换一次。

Replacing the oil one month after the first use and every six months there after.

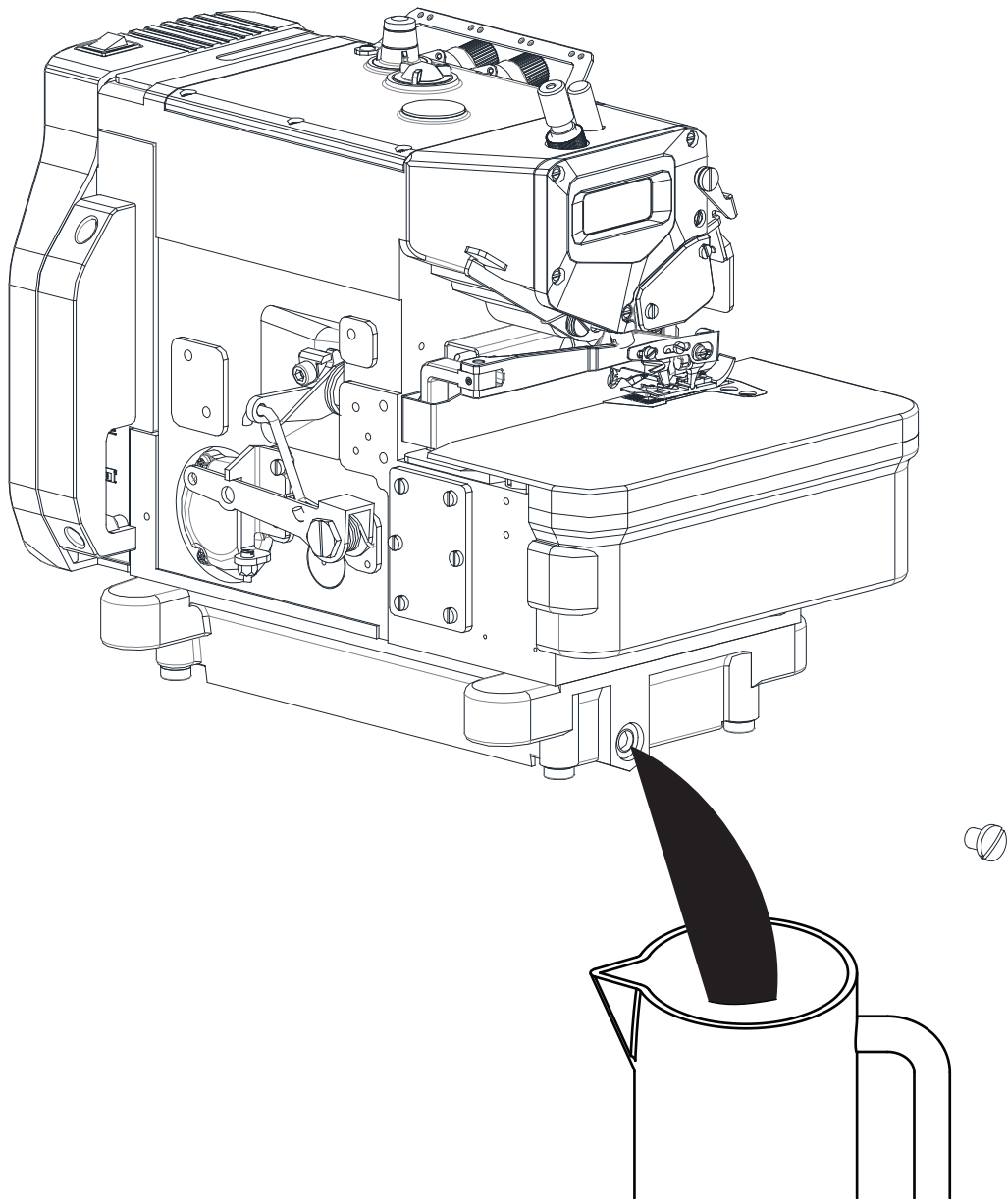

下刀片的更换 Replacing the lower knife

卸下下刀片

To remove the lower knife

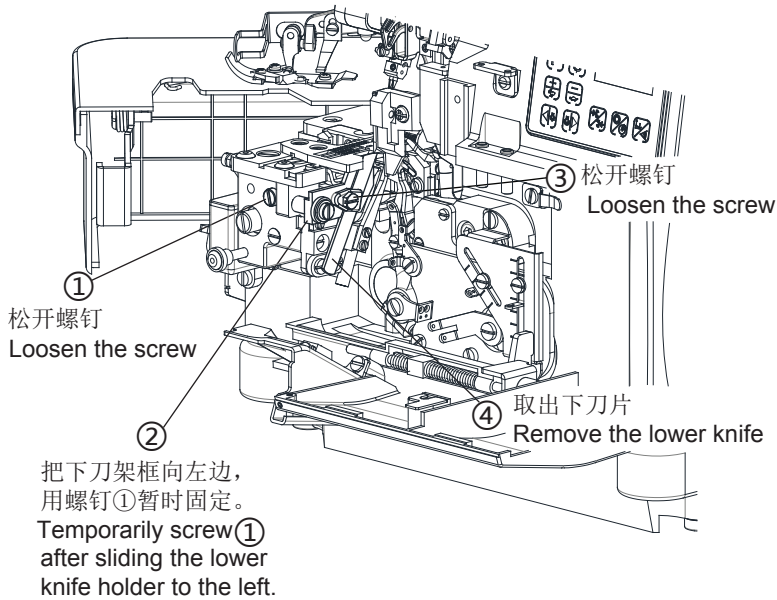

下刀片正确的研磨角度
Correct angles to resharpen the lower knife

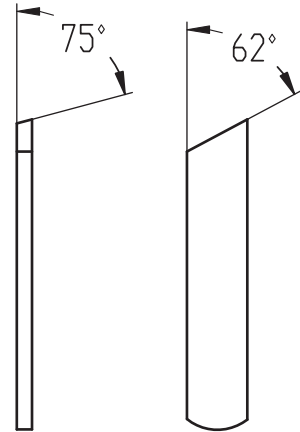

安装下刀片

To replace the lower knife

转动手轮将上刀移动对准如右图所示位置。

Turn the hand wheel as the drawing on the right figure.

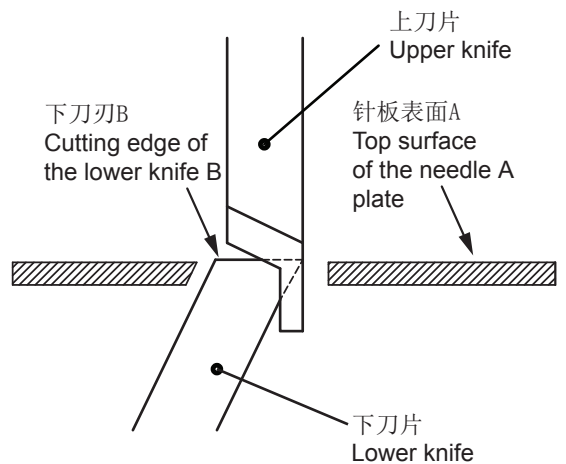
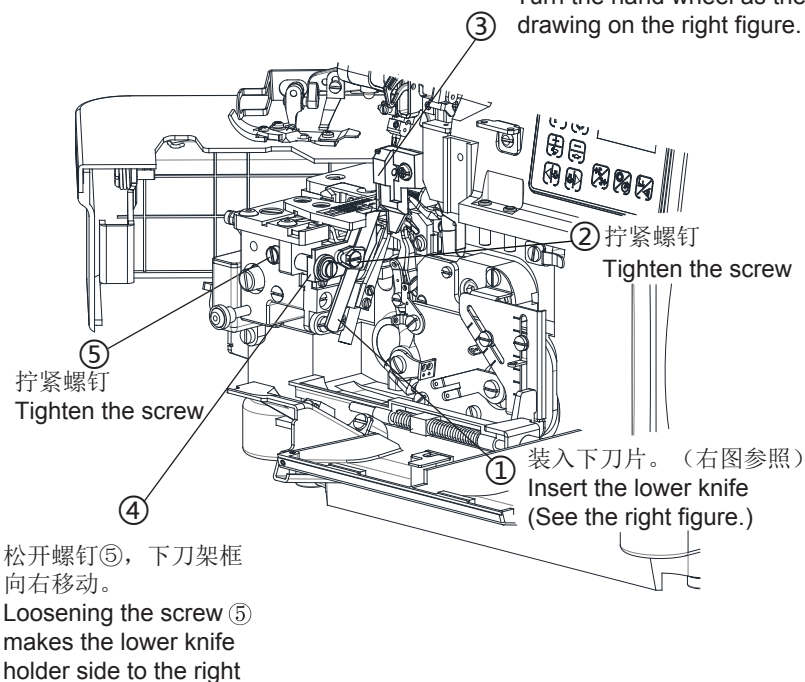

使针板表面A与下刀刃B处于相同水平位置。
Level of [A]=Level of [B]

装好下刀片后进行剪线，确认剪线状况。
Check cutting action of knife.

1. 机壳部件/HOUSING FRAME

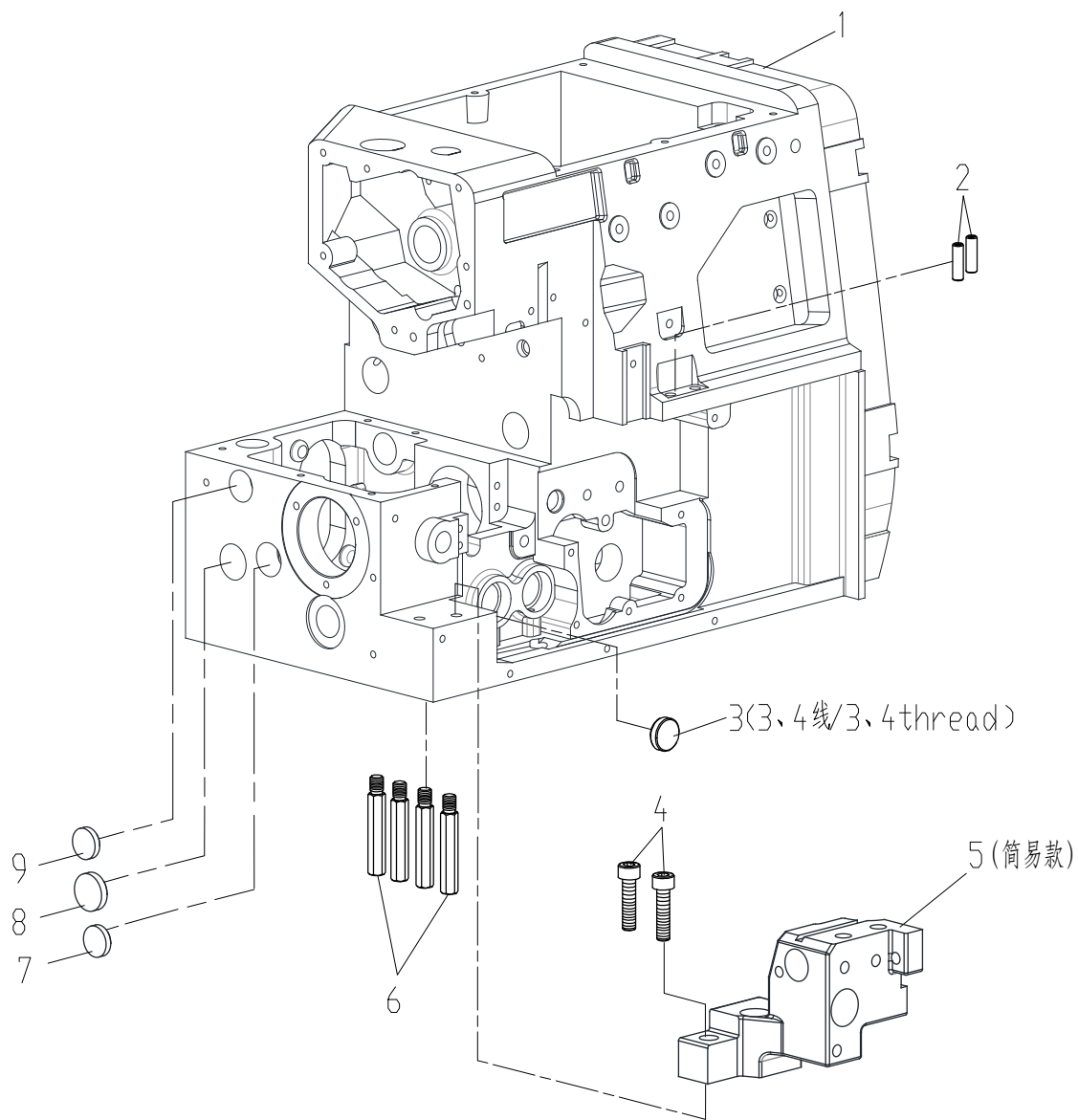

1. 机壳部件/HOUSING FRAME

序号 No.	件号 Parts No.	名称	Description	数量 QT.
1	20024761	机壳敲套组件	housing	1
2	10008983	过线套管	threading pipe	2
3	10013138	橡胶塞	rubber plug	1
4	10003055	螺钉	screw	2
5	10057488	下刀座（简易款）	lower knife bed(economical type)	1
6	10011847	机壳支柱	support for housiong	4
7	10012268	橡胶塞	rubber plug	1
8	10010443	橡胶塞	rubber plug	1
9	10010277	橡胶塞	rubber plug	1

2. 外罩部件(1)/OUT COVER FRAME(1)

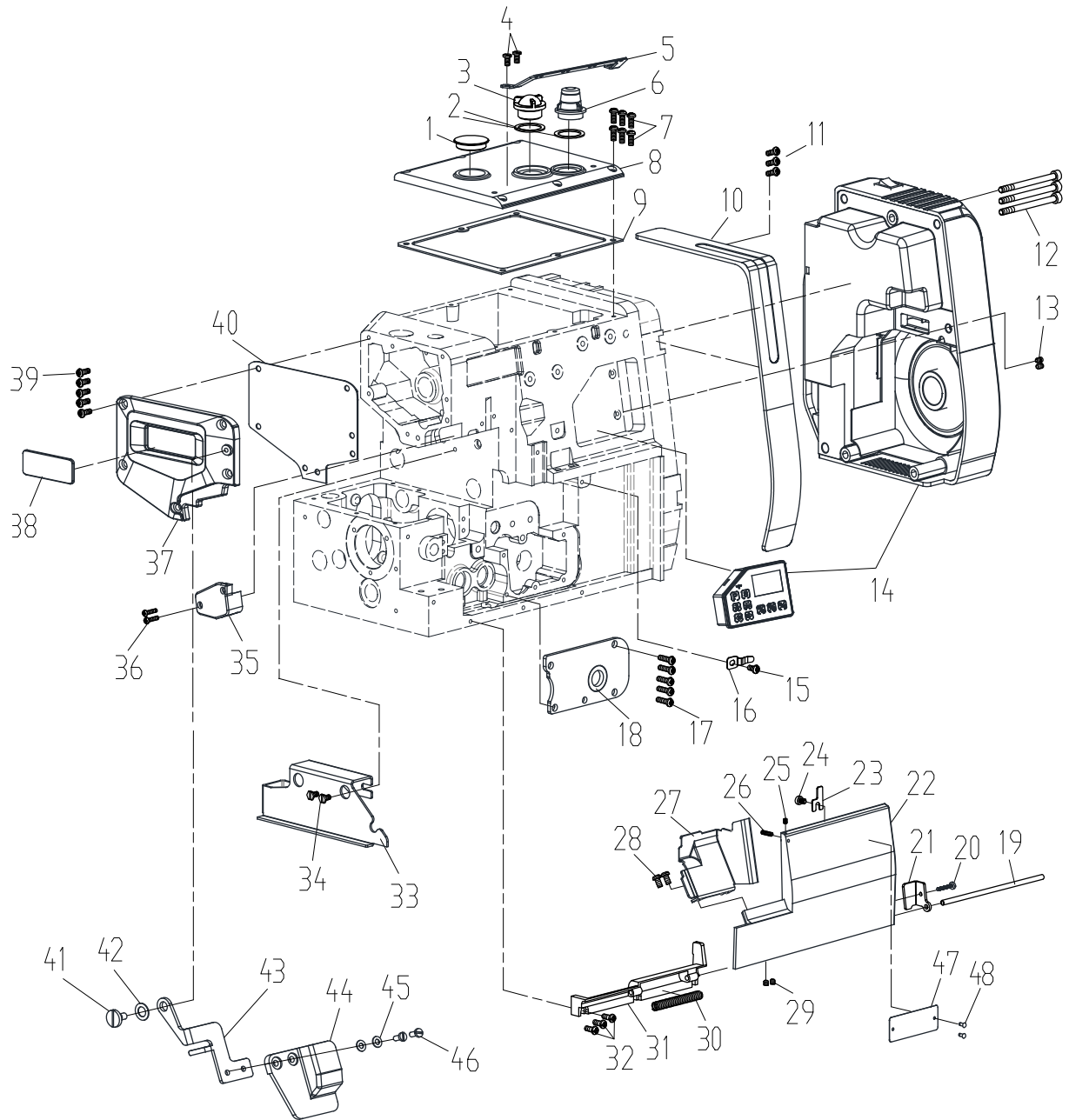

2. 外罩部件(1)/OUT COVER FRAME(1)

序号 No.	件号 Parts No.	名称	Description	数量 QT.
1	10045754	橡胶塞	rubber plug	1
2	10009156	油窗橡胶圈	oil window rubber ring	2
3	10008938	油窗	oil window	1
4	10010554	螺钉	screw	2
5	10063871	过线架	a wire frame	1
6	10062483	油窗	oil window	1
7	10009104	螺钉	screw	6
8	20023697	上盖	upper cover	1
9	10062480	上盖密封垫	seal cushion for upper cover	1
10	10071450	装饰条	trim strip	1
11	10009157	螺钉	screw	3
12	10062719	螺钉	screw	3
13	10009042	螺钉	screw	2
14	☆	简易电控	simple electronic control	1
15	10004171	螺钉	screw	1
16	10033682	弹簧板	spring plate	1
17	10009104	螺钉	screw	5
18	20001597	滑块盖板组件	cover assembly for block	1
19	10062485	销	pin	1
20	10063870	螺钉	screw	1
21	10008911	导向板	guiding plate	1
22	20024766	前盖右	right part of the front cover	1
23	10059247	前盖右挡板	fender for right part of front cover	1
24	10004171	螺钉M4×4.5	screw	1
25	10013019	螺钉M3×4	screw	1
26	10009550	螺钉M3×10	screw	1
27	10064523	前盖中	midle part of the front cover	1
28	10010554	螺钉M4×5.5	screw	2
29	10023463	螺钉M4×4	screw	2
30	10009509	弹簧	spring	1
31	10008880	支架	supporting part	1
32	10009037	螺钉	screw	3
33	10057481	内盖板	the cover plate	1
34	10009157	螺钉	screw	2
35	10064191	B9500机头灯	head lamp	1
36	10011044	螺钉	screw	2
37	20023696	侧盖	side cover	1
38	10070679	面板装饰牌	decorative plate	1
39	10010595	螺钉	screw	5
40	10062593	侧盖密封垫	side gasket	1
41	10009037	螺钉	screw	1
42	10010596	垫圈	washer	1
43	10062486	护板支架	support plate	1
44	10008878	安全罩	safety cover	1
45	10009599	垫圈	washer	2
46	10009600	螺钉	screw	2
47	☆	型号牌	date of the card	1
48	10002840	铆钉	rivet	2

3. 外罩部件(2)/OUT COVER FRAME(2)

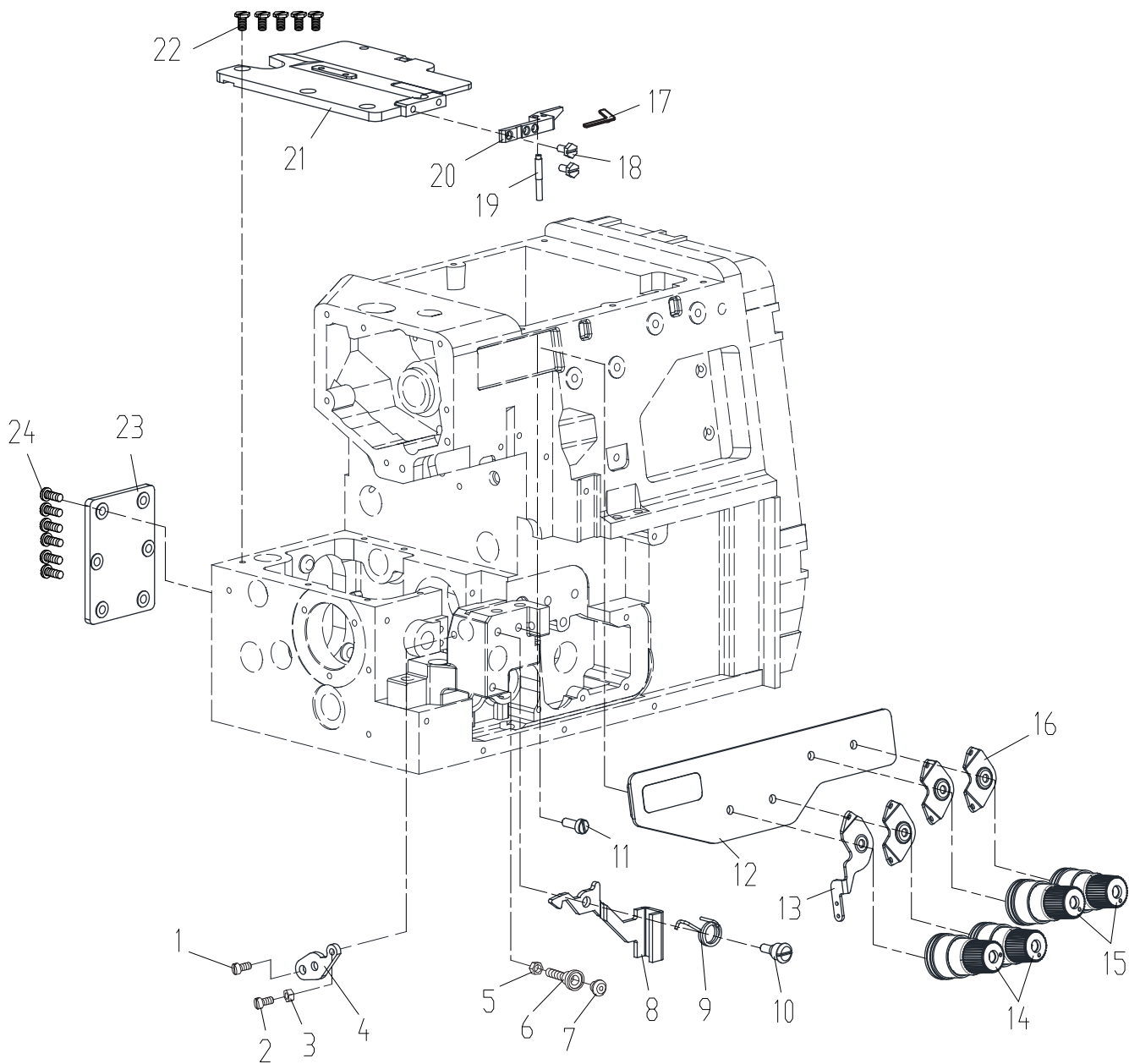

3. 外罩部件(2)/OUT COVER FRAME(2)

序号 No.	件号 Parts No.	名称	Description	数量 QT.
1	10010367	螺钉SM11/64" × 40	screw	1
2	10010568	螺钉SM9/64" × 40	screw	1
3	10009701	扳手螺栓螺母SM9/64" × 40	nut	1
4	10010386	下刀架挡板	plate	1
5	10010370	螺母	nut	1
6	10010369	螺钉	screw	1
7	10010116	针板座胶垫	rubber cushion	1
8	10010296	缝台盖扳手	spanner	1
9	10010371	扳手扭簧	spring	1
10	10010297	螺钉	screw	1
11	10010373	螺钉SM11/64" × 40	screw	1
12	20028799	独立logo灯组件	independent logo lamp cover	1
13	10057504	二孔过线板	threade guide with two hole	1
14	10067010	直针夹线器组件	thread tension assembly	2
15	10067011	弯针夹线器组件	thread tension assembly	2
16	10057503	过线板	threade guide	
17	10010257	橡胶片	rubber plate	1
18	10010245	下螺柱SM9/64" × 40	screw	1
19	10010244	螺钉SM9/64" × 40	screw	2
20	10060167	下盖前弯板	plate	1
21	10057454	左上盖(简易款)	the left upper cover (simple)	1
22	10009157	螺钉M4×7.5	screw	5
23	10010299	后方盖板	cover plate	1
24	10009104	螺钉M4×9.5	screw	6

4. 外罩部件(3)/OUT COVER FRAME(3)

简易款机型用
(Used in the economical type machine)

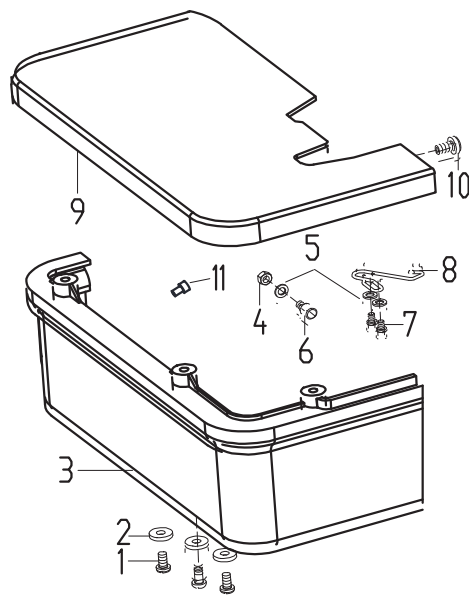

4. 外罩部件(3)/OUT COVER FRAME(3)

序号 No.	件号 Parts No.	名称	Description	数量 QT.
1	10009724	螺钉	screw	3
2	10009725	垫圈	washer	3
3	10003407	围板	side cover	1
4	10009701	扳手螺栓螺母	nut	1
5	10009696	垫圈	washer	3
6	10009700	缝台扳手螺栓	bolt	1
7	10009747	螺钉	screw	2
8	10009774	缝台盖开启卡簧	spring	1
9	10060135	大盖中组件	cloth plate assembly	1
10	10009703	防震胶套 II	rubber cushion	1
11	10009702	防震胶套 I	rubber cushion	1

5. 主轴机构/MAIN SHAFT MECHANISM

序号 No.	件号 Parts No.	名称	Description	数量 QT.
1	10012270	主轴凸轴	shaft with screw	1
2	10012336	轴承左端盖 (5线)	left cover	1
3	10009586	螺钉SM9/64" × 40	screw	3
4	10010567	轴承左端盖 (3、4线)	left cover	1
5	10010569	密封垫	airproof cushion	3
6	10003577	轴承6200-Z/P6	bearing	1
7	10032287	轴芯	wick of shaft	1
8	10010566	螺钉SM7/32 × 32	screw	1
9	10057473	主轴	main shaft	1
10	10059004	平衡块	balance block	2
11	10009625	螺钉M3 × 7.5	screw	4
12	10008898	主轴卡圈	main shaft ring	1
13	10071061	轴承	bearing	1
14	10057502	蜗杆隔套	worm bush canister	1
15	10009362	蜗杆	worm bush	1
16	10012162	螺钉M5 × 5	screw	1
17	10071060	轴承	bearing	1
18	10055918	右盖垫片	spring washer	1
19	10055917	螺纹套	bush mounted in screw	1
20	10009360	O型圈1.8 × 16.7	o ring	1
21	10055919	O型圈	o ring	1
22	10055920	右盖	right cover	1
23	10010594	螺钉M4 × 7.5	screw	3
24	10065664	ZJ950E扁电机(新)	moter assembly	1
25	10005537	5弹簧垫圈	spring washer	4
26	10053435	螺钉M5 × 25	screw	4
27	10064530	手轮组件	hand wheel assembly	1
28	10012162	螺钉M5 × 5	screw	2

6. 针杆传动机构(1)/NEEDLE DRIVE MECHANISM(1)

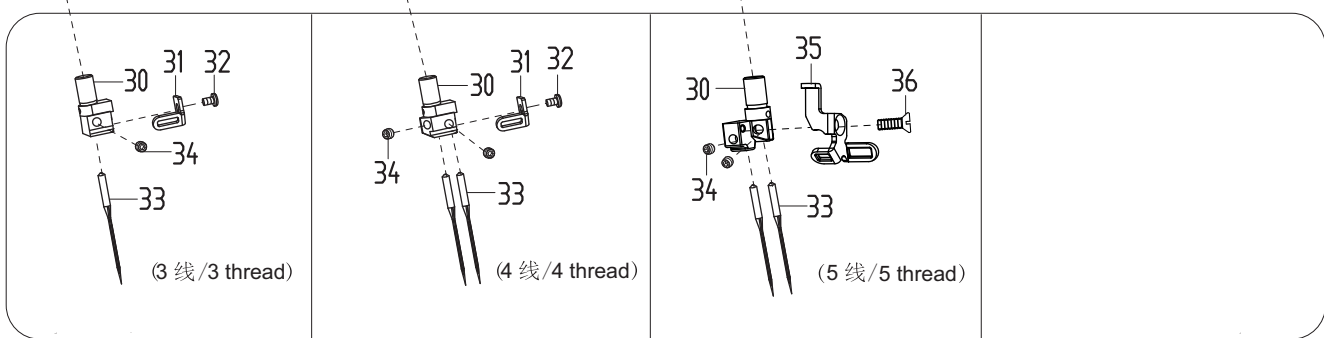
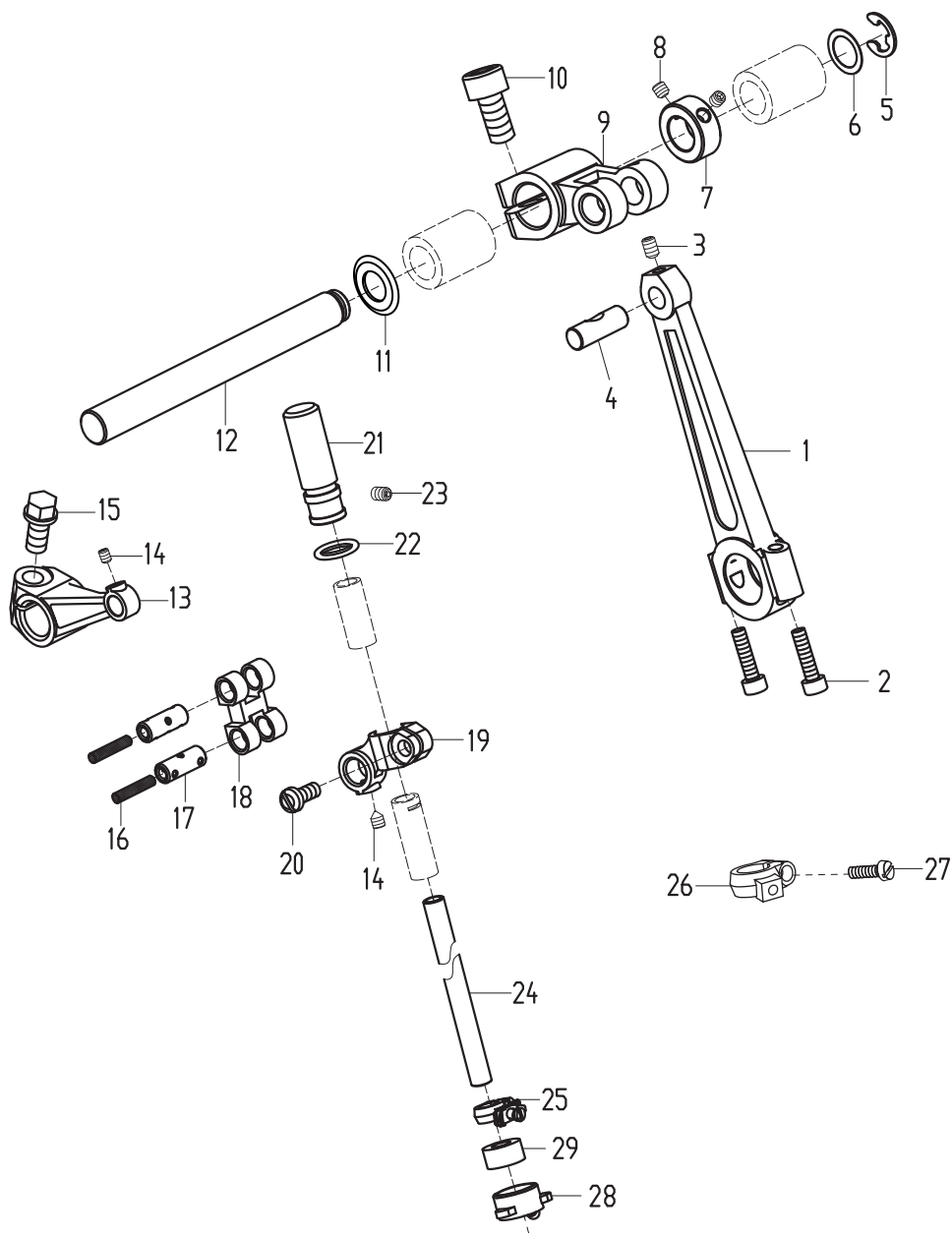

6. 针杆传动机构(1)/NEEDLE DRIVE MECHANISM(1)

序号 No.	件号 Parts No.	名称	Description	数量 QT.
1	10057487	直针传动连杆	link rod	1
2	10004136	螺钉 M4×20	screw	2
3	10009109	螺钉 M4×6	screw	1
4	10009432	直针连杆销 7×21	pin	1
5	10009239	挡圈 7×14×0.8	retaining ring	1
6	10052903	垫圈	washer	1
7	10009231	挡圈 11×19×8	retaining ring	1
8	10023463	螺钉 M4×4	screw	2
9	10057474	直针传动轴曲柄	crank	1
10	10009164	螺钉 M6×0.75×12	screw	1
11	10010112	油封	oil seal	1
12	10057475	直针传动轴	driving shaft of the needle	1
13	10059891	针杆曲柄	crank	1
14	10009240	螺钉 M3×4	screw	2
15	10009245	螺钉 M6×0.75×12	screw	1
16	10008090	φ3油线	oil wick	3
17	10009241	销 φ6.35×16.5	pin	2
18	10009242	针杆双脚古	link rod	1
19	10057468	针杆连接头	clamp of needle bar	1
20	10009115	螺钉 M3.5×8	screw	1
21	10008997	针杆帽	cap	1
22	10009608	O形圈 φ6×φ2	o ring	1
23	10023463	螺钉 M4×4	screw	1
24	10058137	针杆	needle bar	1
25	20001536	针夹头组件	needle holder assembly	1
26	10009344	针夹头夹	needle holder collet	1
27	10010888	螺钉 M3×6.6	screw	1
28	10061407	针杆回油套	returning oil bush	1
29	10057758	针杆回油套毛毡	felt	1
30	*	针夹头	needle holder	1
31	10009339	针夹头过线板	thread guide plate	1
32	10009422	螺钉 M2×2.8	screw	1
33	*	机针	needle	1
34	10009255	螺钉 SM1/8"×44	screw	*
35	10009644	针夹头过线板	thread guide plate	1
36	10009664	螺钉 M2	screw	1
		*:参看专用件表/see the guage list		

7. 针杆传动机构(2) / NEEDLE DRIVE MECHANISM(2)

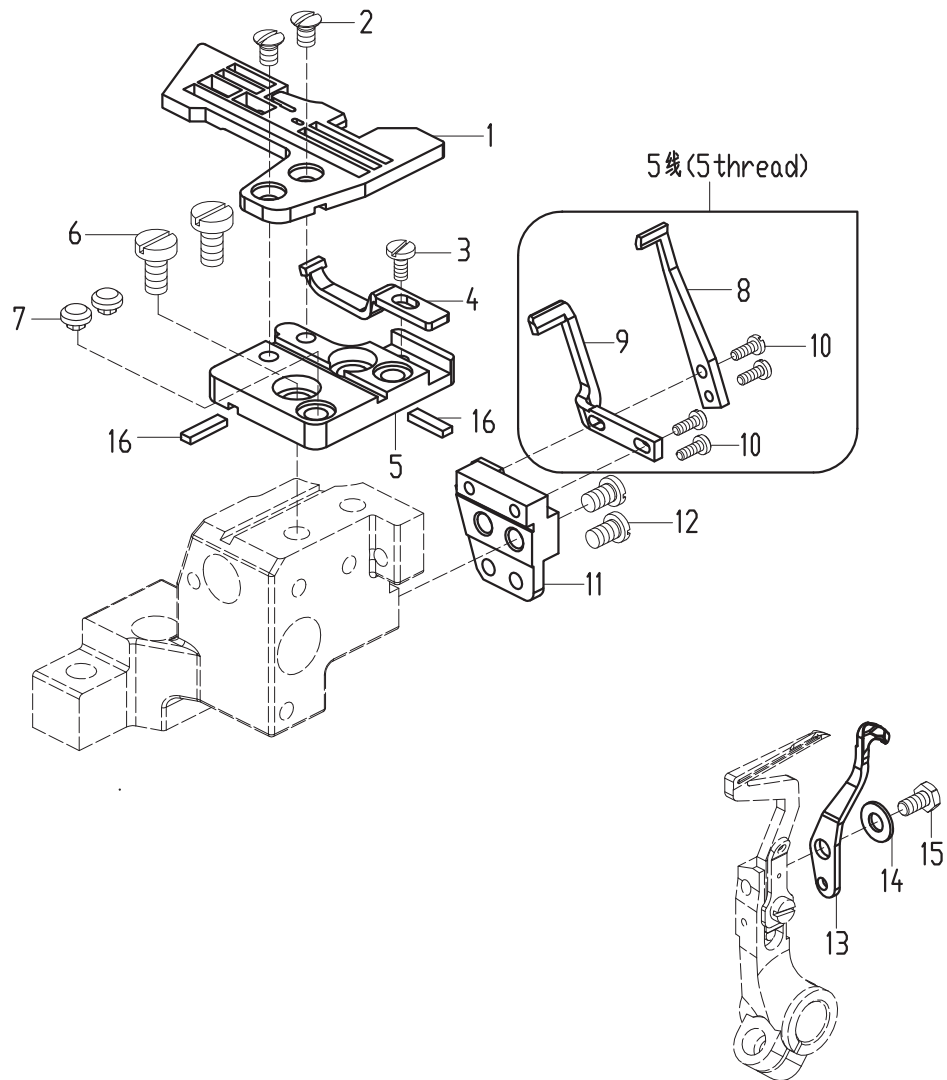

8. 上弯针传动机构/UPPER LOOPER DRIVE MECHANISM

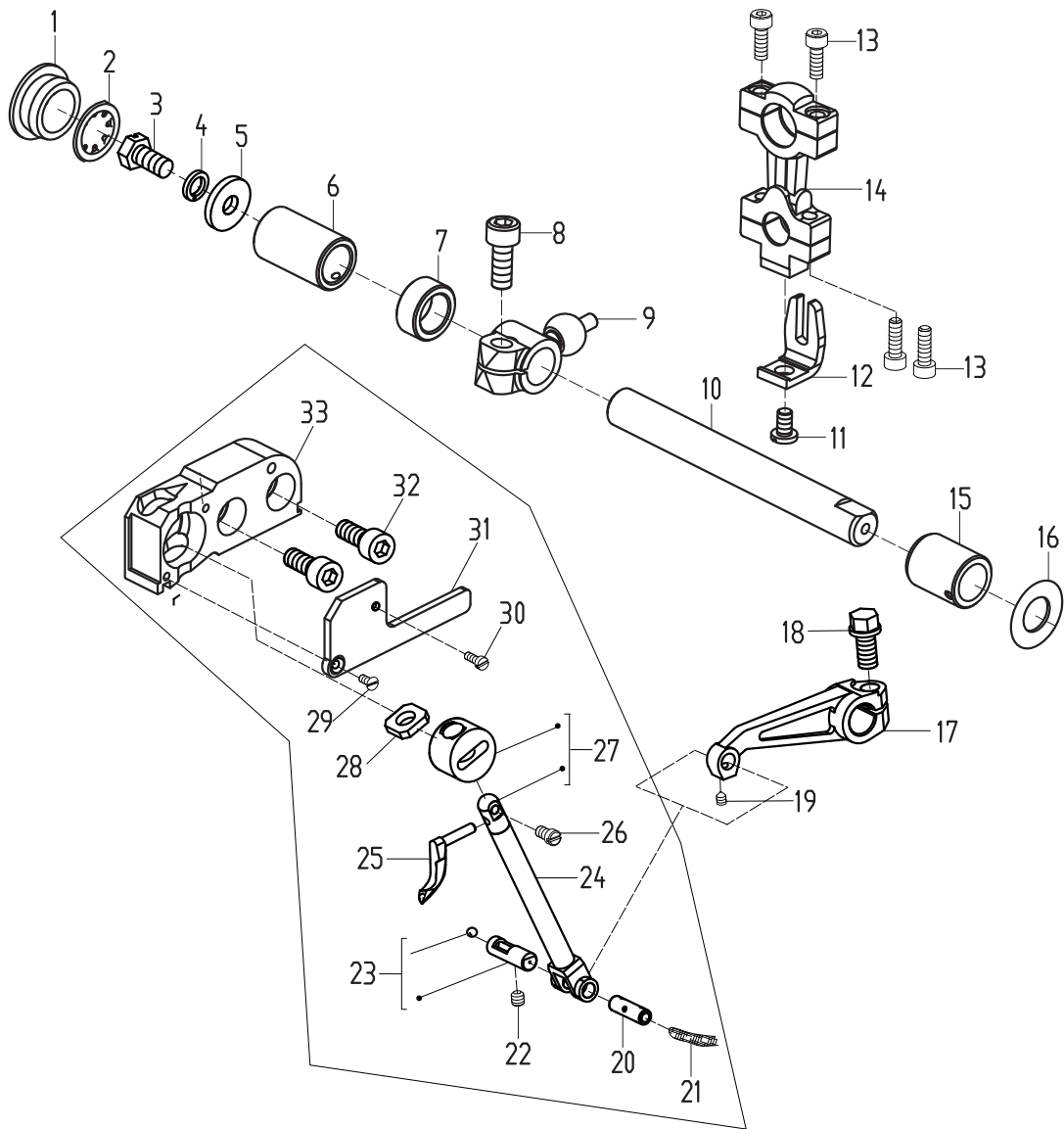

8. 上弯针传动机构/UPPER LOOPER DRIVE MECHANISM

序号 No.	件号 Parts No.	名称	Description	数量 QT.
1	10039396	橡皮塞	plug	1
2	10039397	挡油架	plate for retaining oil	1
3	10009486	螺钉 SM11/64"×40	screw	1
4	10005537	5弹簧垫圈	spring washer	1
5	10009999	4.6 垫圈	washer	1
6	10009124	轴套	bushing	1
7	10010366	间隔套	retaining ring	1
8	10010045	螺钉 SM15/64"×28	screw	1
9	10010013	上弯针球曲柄	crank bush with ball head	1
10	10010379	上弯针轴	shaft	1
11	10010308	螺钉 SM11/64"×40	screw	1
12	10002415	曲柄限位板	guide plate	1
13	10004136	螺钉 M4	screw	4
14	10002414	上弯针连杆	connecting rod	1
15	10059624	轴套	bushing	1
16	10010112	O形圈	o ring	1
17	10004007	上弯针轴曲柄	crank	1
18	10010381	螺钉 SM15/64"×28	screw	1
19	10010196	螺钉 M3×3	screw	1
20	10003970	上弯针摇杆销	pin	1
21	10008076	φ 3.5 油线	oil wick	1
22	10009074	螺钉 M4×4	screw	1
23	20000790	给油销组件	oil pin assembly	1
24	10004010	上弯针摇杆	sliding bar	1
25	10010197	螺钉 SM9/64"×40	screw	1
26	*	上弯针	upper looper	1
27	10004012	圆滑块	slide block	1
28	10011151	毛毡	felt	1
29	10004008	螺钉 SM1/8"×44	screw	1
30	10009747	螺钉 SM1/8"×44	screw	1
31	10004009	摇杆座盖板	cover plate	1
32	10002082	螺钉 M6×15	screw	2
33	10004011	上弯针摇杆座	bracket	1
		*: 参看专用件表/see the guage list		

9. 下弯针传动机构/LOWER LOOPER DRIVE MECHANISM

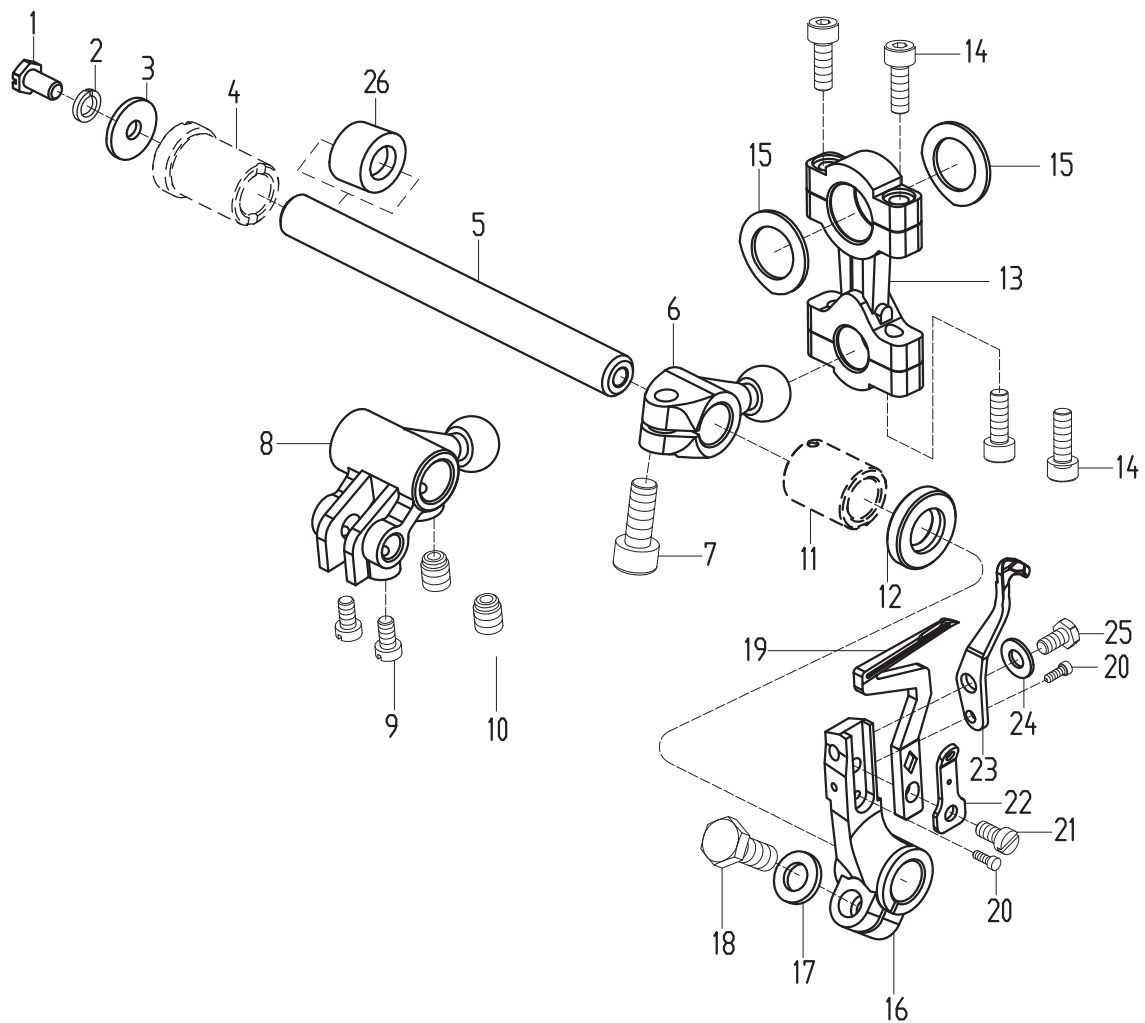

9. 下弯针传动机构/LOWER LOOPER DRIVE MECHANISM

序号 No.	件号 Parts No.	名称	Description	数量 QT.
1	10009486	螺钉 SM11/6 4"×40	screw	1
2	10005537	5弹簧垫圈	spring washer	1
3	10009999	4.6垫圈	washer	1
4	10009125	轴套	bushing	1
5	10010380	下弯针轴 (3、4线)	shaft of lower looper	1
	10074029	下弯针轴 (5线)	shaft of lower looper	1
6	10010012	下弯针球曲柄	bushing	1
7	10010045	螺钉 SM15/6 4"×28	screw	1
8	10012337	下弯针球曲柄	crank	1
9	10010197	螺钉 SM9/6 4"×40	screw	2
10	10000881	螺钉 SM1/4"×40	screw	2
11	10009127	轴套	bushing	1
12	10010000	油封 $\phi 10 \times \phi 19 \times 4$	oil seal	1
13	10008791	下弯针连杆	link	1
14	10004136	螺钉 M4	screw	4
15	10003909	挡圈	retaining ring	2
16	10010001	下弯针架	lower looper holder	1
17	10002995	6垫圈	washer	1
18	10010381	螺钉 SM15/6 4"×28	screw	1
19	10010003	下弯针	lower looper	1
20	10010002	铆钉 $\phi 1.9 \times 5.5$	rivet	2
21	10010568	螺钉 SM9/6 4"×40	screw	1
22	10010004	下弯针过线板	thread guide plate	1
23	10010113	下弯针护针挡	guard needle	1
24	10009725	4.5垫圈	washer	1
25	10010114	螺钉 SM9/6 4"×40	screw	1
26	10010366	间隔套	interval ring	1

10. 链弯针机构/CHAINSTITCH LOOPER FRAME

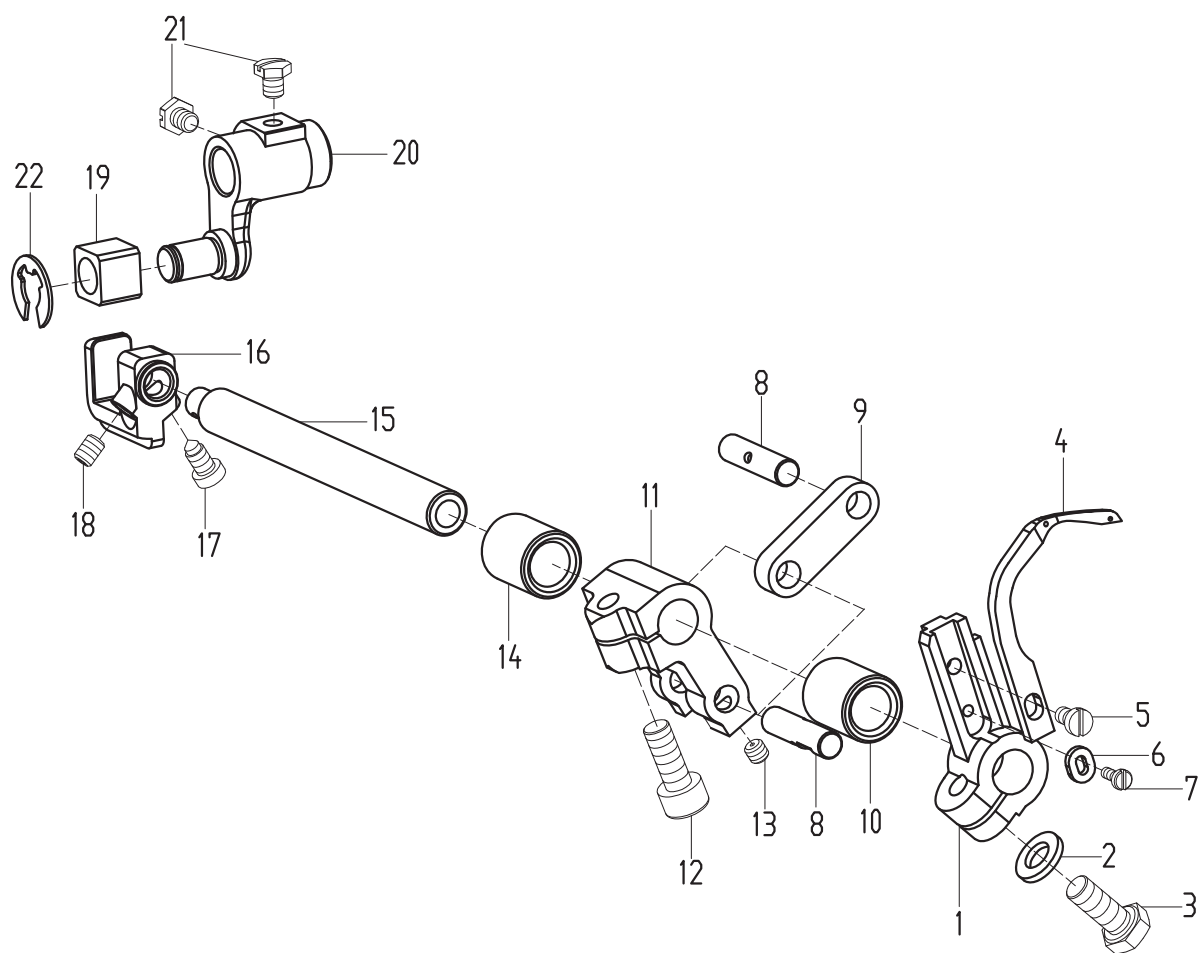

10. 链弯针机构/CHAINSTITCH LOOPER MECHANISM

序号 No.	件号 Parts No.	名称	Description	数量 QT.
1	10012274	链弯针架	looper holder	1
2	10002995	垫圈	washer	1
3	10010381	螺钉SM15/64"×28	screw	1
4	10012275	链弯针	chainstitch looper	1
5	10009580	螺钉SM9/64"×40	screw	1
6	10012350	链弯针调节垫	regulating washer	1
7	10012324	螺钉SM3/32"×56	screw	1
8	10012271	调节板销	pin	2
9	10009116	链弯针连杆	link	1
10	10008894	轴套	bushing	1
11	10012272	链弯针曲柄	crank	1
12	10010045	螺钉SM15/64"×28	screw	1
13	10013590	螺钉SM11/64"×40	screw	1
14	10008799	轴套	bushing	1
15	10012367	链弯针轴	shaft	1
16	10012021	弯针摆轴接杆	driving lever	1
17	10012062	螺钉SM11/64"×40	screw	1
18	10012016	螺钉SM11/64"×40	screw	1
19	10012276	链弯针滑块	block	1
20	10012368	驱动曲柄	driving crank	1
21	10010291	螺钉	screw	2
22	10009655	挡圈	ring	1

11. 打线凸轮机构/CAM ASSEMBLY

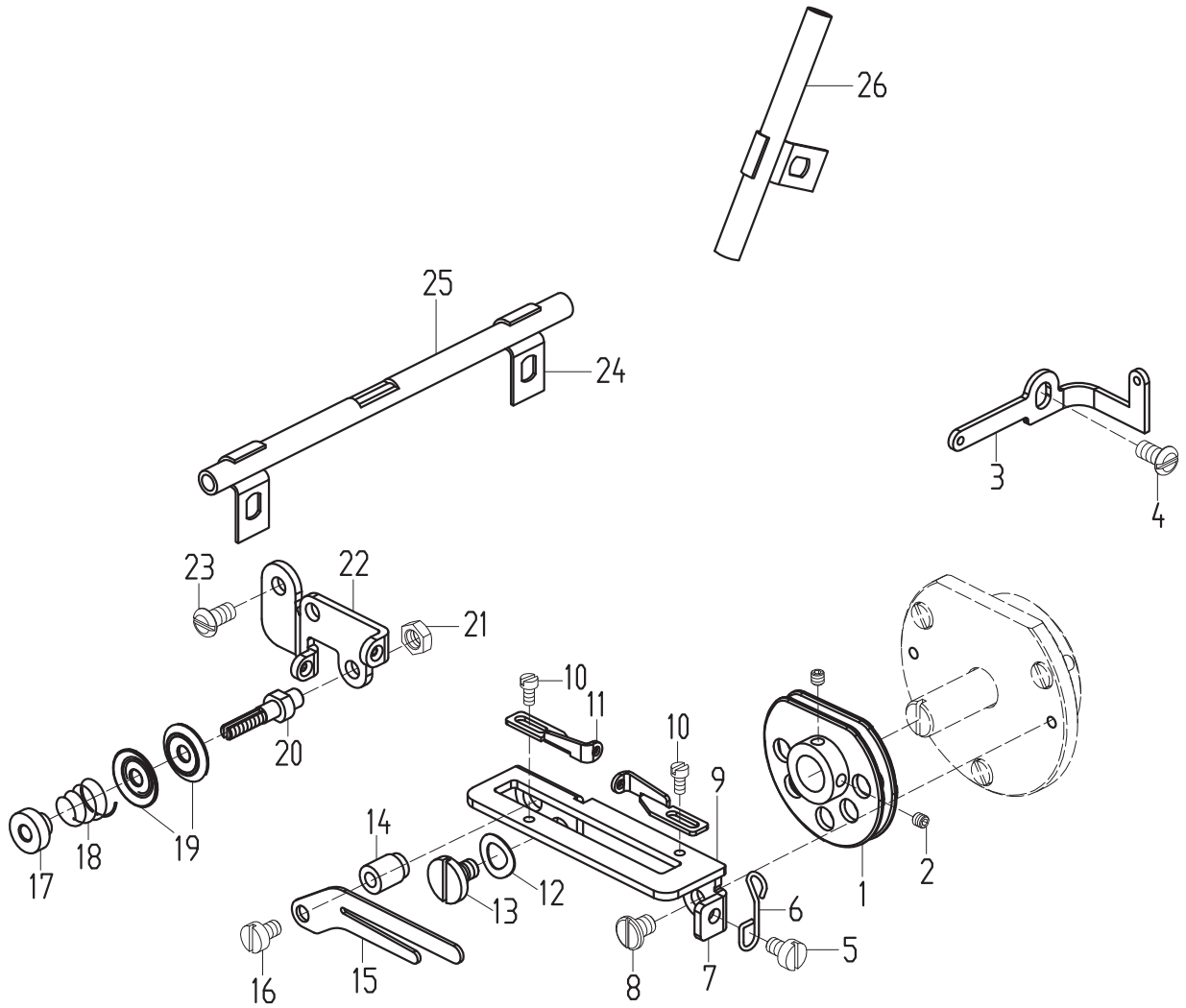

11. 打线凸轮部件/CAM ASSEMBLY

序号 No.	件号 Parts No.	名称	Description	数量 QT.
1	10012361	打线凸轮组件	looper thread take up assembly	1
2	10010196	螺钉	screw	2
3	10012386	双孔过线板	thread guide	1
4	10010120	螺钉	screw	1
5	10009363	螺钉SM9/64"×40	screw	1
6	10012385	过线环	thread guide hook	1
7	10012384	限位板	guide plate	1
8	10010308	螺钉	screw	1
9	10005470	导线架组件	bracket assembly	1
10	10011033	螺钉	screw	2
11	10012381	过线板	thread guide	2
12	10010596	垫圈	washer	2
13	10012382	螺钉	screw	1
14	10005471	导线板固定柱	stand pin	1
15	10012383	导线板	thread guide	1
16	10009363	螺钉	screw	1
17	10012389	调压螺母	knob	1
18	10010612	弹簧	spring	1
19	10033739	夹线板	tension disc	2
20	10012388	开口螺栓	screw	1
21	10010370	螺母	nut	1
22	10012387	夹线器架	bracket	1
23	10010006	螺钉	screw	1
24	10010118	过线管压板	bracket	3
25	10010604	链弯横过线管	thread guide pipe	1
26	10033698	链弯竖过线管	thread guide pipe	1

12. 差动送布机构(1)/DIFFERENTIAL FEED ASSEMBLY(1)

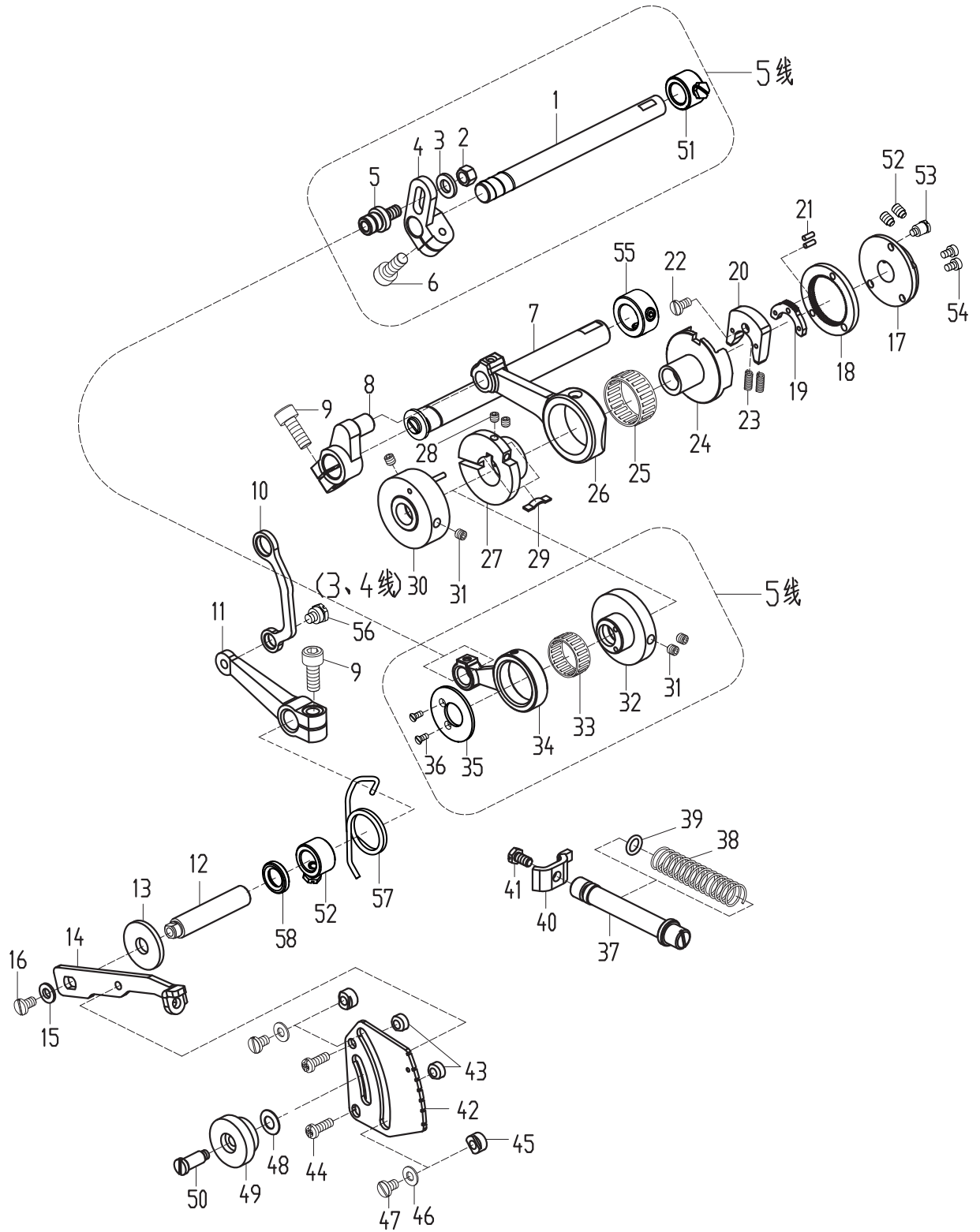

12. 差动送布机构(1)/DIFFERENTIAL FEED ASSMEBLY(1)

序号 No.	件号 Parts No.	名称	Description	数量 QT.
1	10012352	横轴曲柄轴	feed shaft	1
2	10012355	螺母	nut	1
3	10002995	垫圈	washer	1
4	10012353	横轴曲柄	crank	1
5	10012354	曲柄调整销	eccentric pin	1
6	10010045	螺钉	screw	1
7	10010871	送布轴	shaft	1
8	10010878	送布曲柄	crank	1
9	10010045	螺钉SM15/64"×28	screw	2
10	10010890	差动连杆	link	1
11	10010889	差动曲柄	crank	1
12	10010872	差动机构轴	shaft	1
13	10010873	8.2垫圈	washer	1
14	10057480	差动调节杆	rod	1
15	10009725	4.5垫圈	washer	1
16	10010308	螺钉SM11/64"×40	screw	1
17	10003947	内齿圈座	stand	1
18	10003949	内齿圈	slide block with inner teeth	1
19	10003948	扇齿	fan gear	1
20	10003951	扇齿板	fan gear plate	1
21	10002878	销φ2×6	pin	1
22	10013035	螺钉SM3/32"×56	screw	1
23	10003953	弹簧	spring	2
24	10003955	齿板滑道体	cam	1
25	10003941	轴承	bearing	1
26	10003942	针距轴连杆	feed link	1
27	10003938	偏心轴套	cam	1
28	10003939	螺钉M3×6	screw	2
29	10003940	板簧片	spring plate	1
30	10006868	送布凸轮挡圈组件(3、4线)	collar assembly	1
31	10010078	螺钉SM11/64"×40	screw	4
32	10012132	曲柄连杆凸轮(5线)	link cam	1
33	10012122	轴承	bearing	1
34	10012121	横轴连杆	link	1
35	10012356	挡圈	cover	1
36	10004958	螺钉	screw	2
37	10057512	针距调节按钮轴	push button	1
38	10010881	O形圈	O ring	1
39	10039586	弹簧	spring	1
40	10010912	针距调节卡板	press board	1
41	10009486	螺钉	screw	1
42	10060170	调节指示板	plate	1
43	10009200	垫圈4.2×8×4.5	washer	2
44	10009037	螺钉M4×12	screw	2
45	10010894	调节滑块	block	2
46	10012836	垫圈φ4.6×φ9.7×0.8	washer	2
47	10010120	螺钉SM11/64"×40	screw	2
48	10009564	垫圈	washer	1
49	10009565	螺母M6×0.75	nut	1
50	10009562	螺钉	screw	1

12. 差动送布机构(1)/DIFFERENTIAL FEED ASSEMBLY(1)

序号 No.	件号 Parts No.	名称	Description	数量 QT.
51	20001566	差动曲柄挡圈组件	retain ring assembly	2
52	10010078	螺钉SM11/64"×40	screw	2
53	10003946	螺钉SM9/64"×40	screw	1
54	10003943	螺钉SM1/8"×44	screw	2
55	20001768	送布轴挡圈组件	retain ring assembly	1
56	10010840	螺钉SM11/64"×40	screw	1
57	10010892	弹簧	spring	1
58	10008988	油封	oil seal	1

13. 差动送布机构(2)/DIFFERENTIAL FEED ASSEMBLY(2)

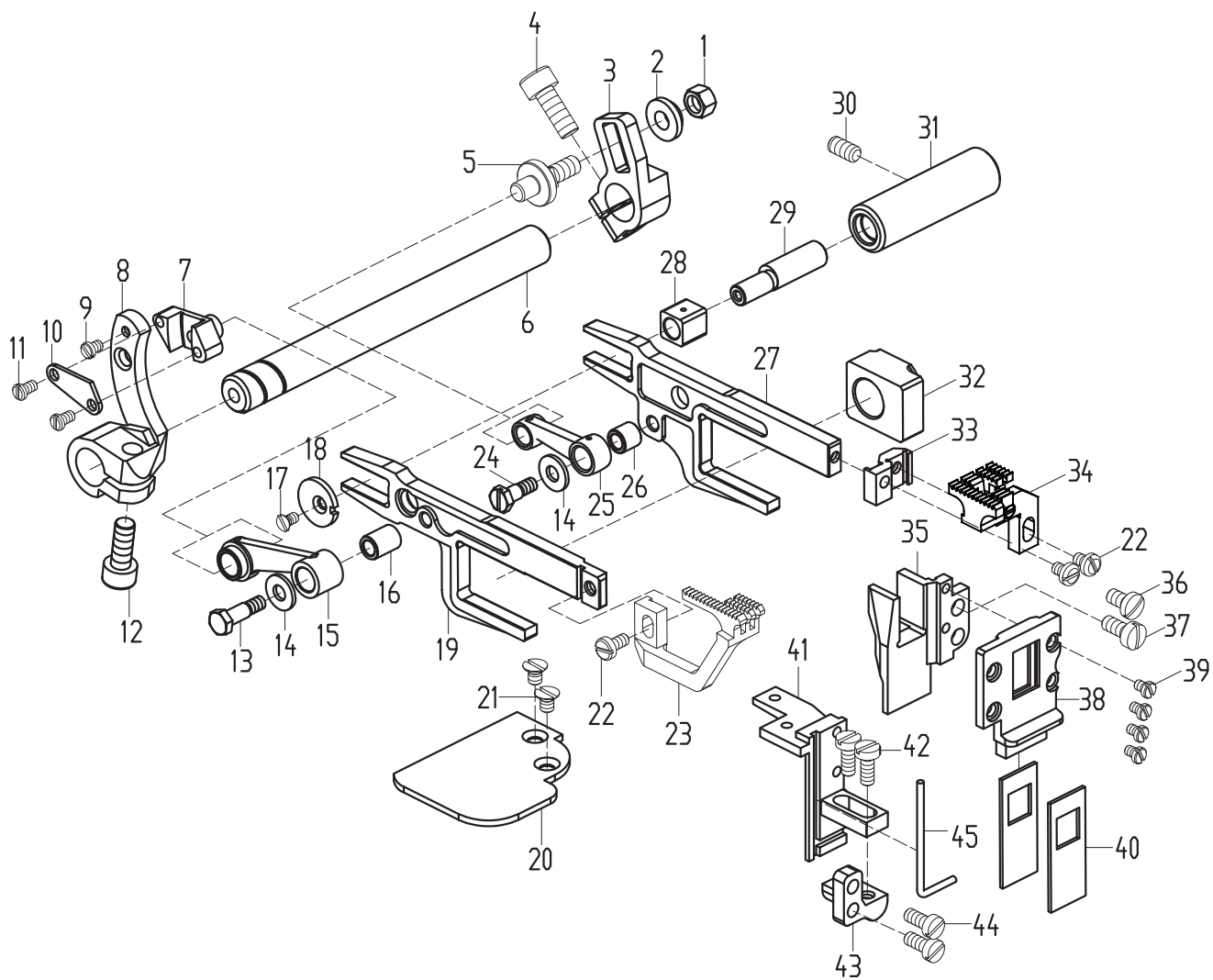

13. 差动送布机构(2)/DIFFERENTIAL FEED ASSEMBLY(2)

序号 No.	件号 Parts No.	名称	Description	数量 QT.
1	10012355	螺母	nut	1
2	10010876	垫圈	washer	1
3	10010875	送布调整曲柄	crank	1
4	10010045	螺钉	bolt	1
5	10010911	送布连杆偏心轴	eccentric pin	1
6	10010871	送布轴	feed shaft	1
7	10004384	曲柄滑块	crank block	1
8	10004379	差动调节曲柄	crank	1
9	10009747	螺钉SM1/8"×44	screw	1
10	10004381	曲柄滑块盖板	cover for crank block	1
11	10010943	螺钉SM1/8"×44	screw	2
12	10010045	螺钉SM15/64"×28	screw	1
13	10033716	螺钉	screw	1
14	10042559	垫圈	washer	2
15	10010920	差动牙架连杆	differential feed link	1
16	10010915	差动牙架连杆套	bushing	1
17	10042559	螺钉	screw	1
18	10009627	垫圈	washer	1
19	10010884	差动牙架	differential feed bar	1
20	10010306	上挡油板	plate for retaining oil	1
21	10010307	螺钉SM1/8"×44	screw	2
22	10010942	螺钉	screw	3
23	*	差动送布牙	differential feed dog	1
24	10010919	螺钉	screw	1
25	10010885	送布牙架连杆	main feed link	1
26	10010918	送布牙架连杆套	bushing	1
27	10010914	送布牙架	main feed bar	1
28	10010946	差动送布滑块	block	1
29	10042555	滑块偏心轴	eccentric pin	1
30	10010291	螺钉	screw	1
31	10010882	轴套	bushing	1
32	10010939	抬牙滑块	feed bar lift	1
33	10010886	送布牙架连接板	link plate	1
34	*	主送布牙组件	main feed dog	1
35	10010445	牙架导轨	feed bar guide	1
36	10010006	螺钉	screw	1
37	10010279	螺钉	screw	1
38	10010446	牙架导轨挡板	guide	1
39	10009747	螺钉	screw	4
40	10010280	活动油封	oil seal	2
41	10010448	挡板支架	bracket	1
42	10013051	螺钉	screw	2
43	10057506	挡板支架安装块	block	1
44	10010722	螺钉M4×10	screw	2
45	10010449	挡板密封胶条	seal rubber	1
		*:参看专用件表/see the guage list		

14. 切料机构/KNIFE DRIVE ASSEMBLY

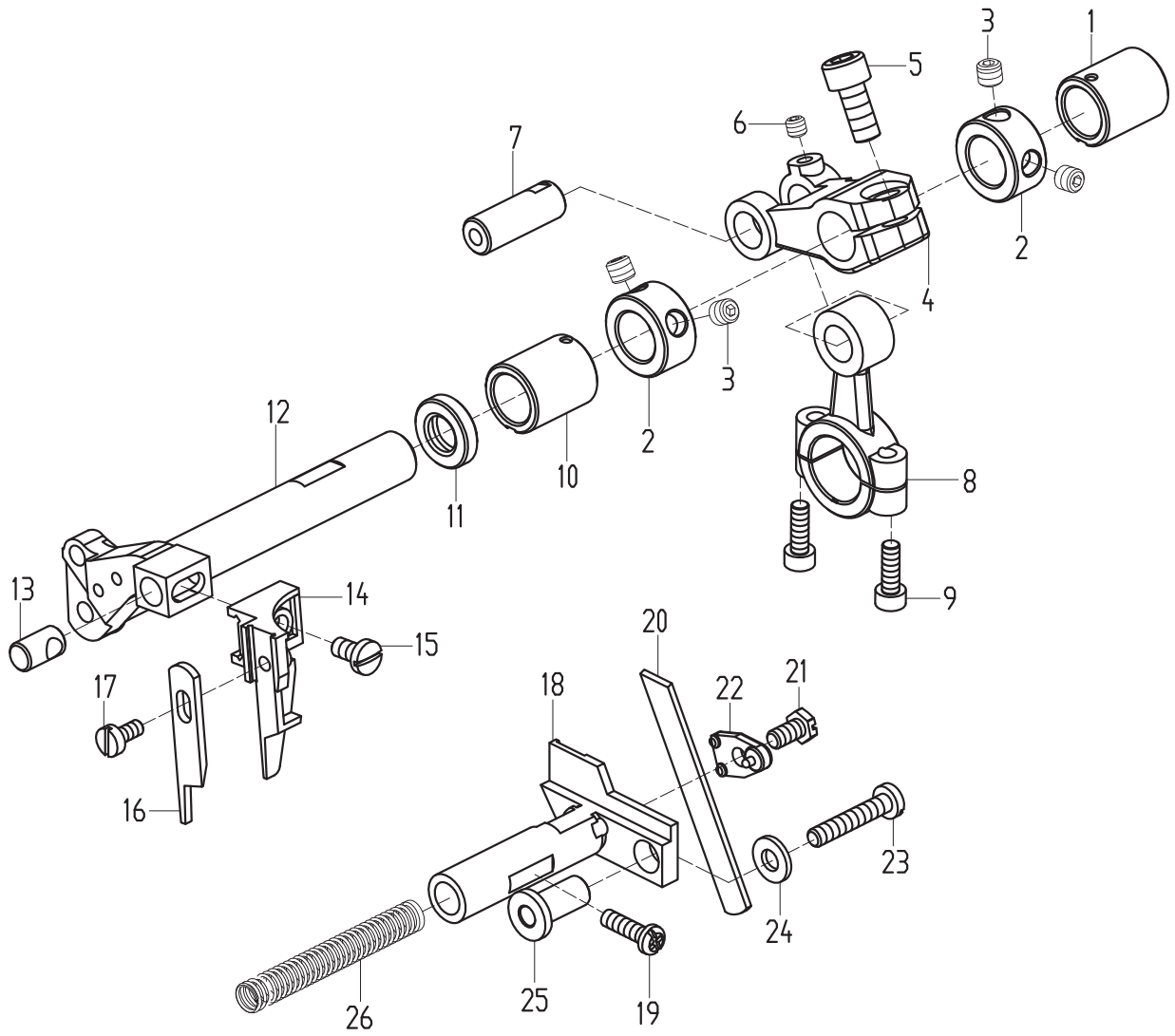

14. 切料机构/KNIFE DRIVE ASSEMBLY

序号 No.	件号 Parts No.	名称	Description	数量 QT.
1	10009120	轴套	bushing	1
2	10010290	挡圈	collar	2
3	10010291	螺钉	screw	4
4	10010046	上刀曲柄	crank	1
5	10010045	螺钉	screw	1
6	10013590	螺钉	screw	1
7	10059626	上刀曲柄销	crank pin for upper	1
8	10010483	上刀轴连杆	connecting rod for upper	1
9	10004136	螺钉	screw	2
10	10009121	轴套	bushing	1
11	10008986	油封	oil seal	1
12	10010289	上刀轴	shaft	1
13	10010346	上刀轴销	pin	1
14	10010347	上刀座(3、4线)	upper blade clamp	1
	10012118	上刀座(5线)	upper blade clamp	1
15	10010367	螺钉	screw	1
16	10010348	上切刀	upper blade	1
17	10010244	螺钉	screw	1
18	10010383	下刀架(3、4线)	lower blade holder	1
	10012119	下刀架(5线)	lower blade holder	1
19	10010367	螺钉	screw	1
20	10010384	下切刀	lower blade	1
21	10009486	螺钉	screw	1
22	10009485	下刀压板	lower blade clamp	1
23	10010388	螺钉	screw	1
24	10012318	垫圈	washer	1
25	10010387	下刀架套筒	bushing	1
26	10010385	弹簧	spring	1

15. 压脚机构/PRESSER FOOT ASSEMBLY

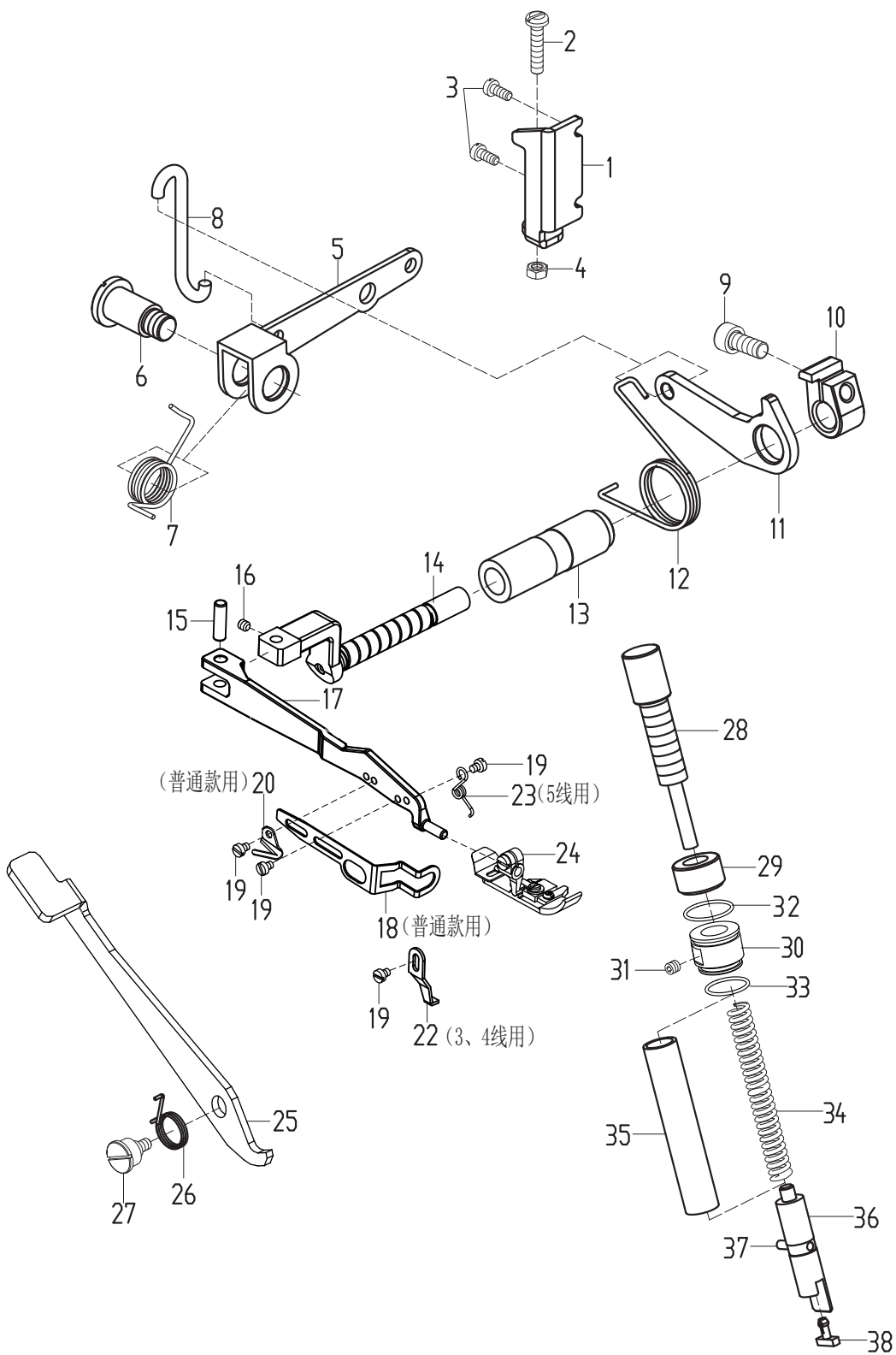

15. 压脚机构/PRESSER FOOT ASSEMBLY

序号 No.	件号 Parts No.	名称	Description	数量 QT.
1	10033723	制动板	plate	1
2	10009623	螺钉\M5×24	screw	1
3	10009104	螺钉M4×9.5	screw	2
4	10009467	螺母M5	nut	1
5	10041532	抬压脚杠杆	foot lift	1
6	10036965	螺钉	screw	1
7	10009036	杠杆扭簧	spring	1
8	10009622	抬压脚拉杆	pulling lever	1
9	10033721	抬压脚连杆	connecting rod	1
10	10037485	抬压脚曲柄	crank	1
11	10009616	螺钉M6×0.75×14	screw	1
12	10037485	扭簧	spring	1
13	10059622	压脚轴套	bush	1
14	10009032	压脚轴	shaft of presser foot lifting	1
15	10009319	销 φ5×17.2	pin	1
16	10014216	螺钉M4×0.5×4	screw	1
17	10061311	压脚臂	arm of presser foot lifting	1
18	10010660	护指罩	cover of protecting finger	1
19	10009529	螺钉M3×3.8	screw	4
20	10011912	割线刀	knife for cutting thread	1
22	10010662	压脚限位板 (3、4线)	plate	1
23	10012120	压脚限位簧 (5线)	spring	1
24	*	压脚组件	presser foot assembly	1
25	10062481	压脚扳手	hand lifter of presser foot	1
26	10063382	压脚扳手扭簧	spring	1
27	10057459	扳手螺钉	screw	1
28	10058290	调压螺钉	screw	1
29	10057465	调压螺母	nut	1
30	10057460	压脚杆螺纹套	screw ring	1
31	10023463	螺钉M4×4	screw	1
32	10057462	O型圈	O ring	1
33	10057464	O型圈	O ring	1
34	10058291	弹簧	spring	1
35	10057461	压脚杆塑料套	plastic ring	1
36	10057455	压脚杆	bar of presser foot	1
37	10002776	销 φ3×16	pin	1
38	10009454	塑料垫	plastic mat	1
		*:参看专用件表/see the guage list		

16. 挑线 • 过线机构/THREAD TAKEUP AND THREADING FRAME

3、4线/3、4thread

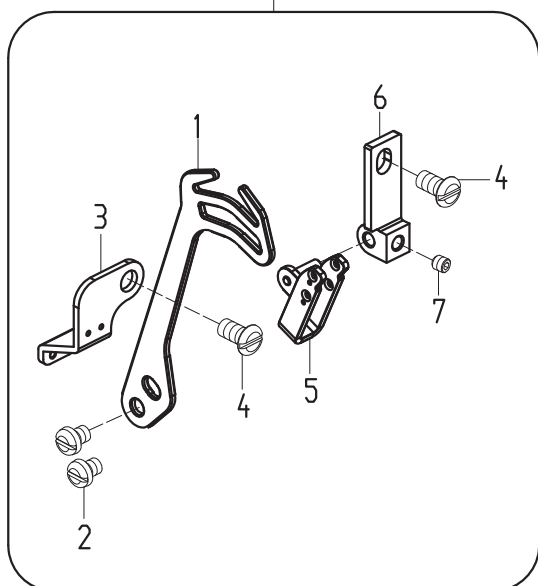

5线/5thread

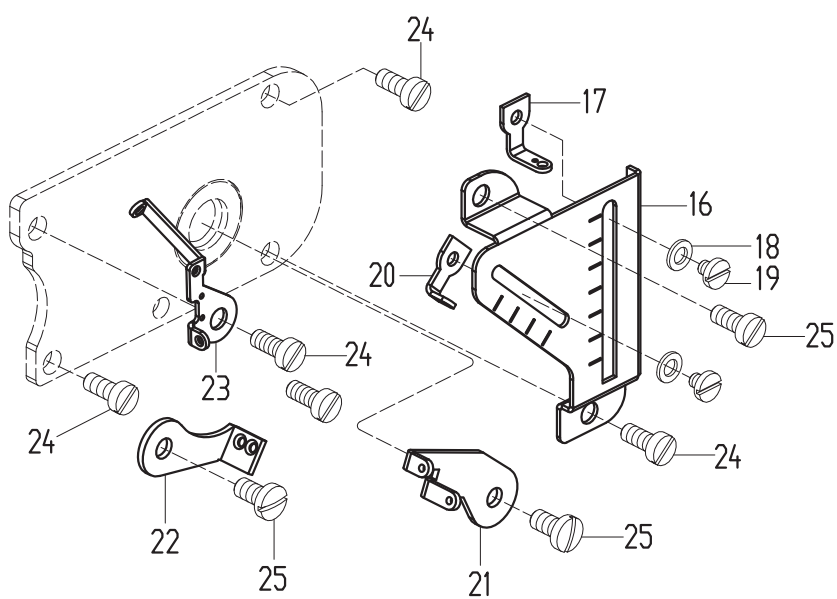
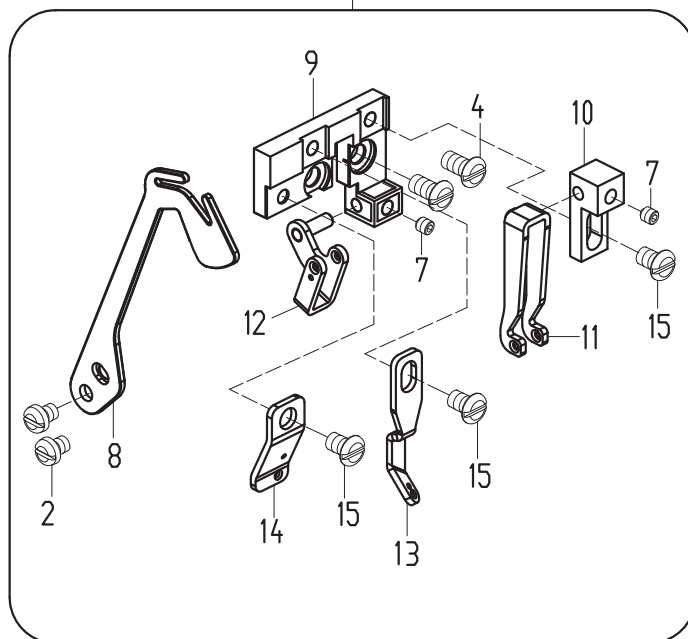

16. 挑线·过线机构/THREAD TAKEUP AND THREADING FRAME

序号 No.	件号 Parts No.	名称	Description	数量 QT.
1	10068379	挑线架	stand of take-uping thread	1
2	10009363	螺钉SM9/64"×40	screw	4
3	10066279	直针过线板	plate	1
4	10010594	螺钉M4×7.5	screw	4
5	10009058	挑线夹组件	thread tension plate assembly	1
6	10009015	挑线夹固定架	stand for thread tension	1
7	10023463	M4×4螺钉	screw	1
8	10068378	挑线架	thread tension stand	1
9	10009639	固定板	fixing plate	1
10	10057518	挑线夹固定架	stand for thread tension	1
11	10002756	上挑线夹组件(5线)	upper thread tension plate	1
12	10009663	下挑线夹组件	down thread tension plate	1
13	10003252	右过线板	right thread guide plate	1
14	10058139	左过线板(5线)	left thread guide plate	1
15	10004171	螺钉M4×4.5	screw	3
16	10011034	调节刻度板	bracket	1
17	10011012	下弯针可调过线板	thread guide plate	1
18	10009696	垫圈φ4×φ7×0.8	washer	2
19	10011013	螺钉SM1/8"×44	screw	2
20	10011035	上弯针可调过线板	thread guide plate	1
21	10011037	上弯针轴两孔挑线板	thread guide plate with two	1
22	10011038	下弯针轴两孔挑线板	thread guide plate with two hole	1
23	10011039	弯针三孔过线板	thread guide plate with three hole	1
24	10009104	螺钉M4×9.5	screw	5
25	10010367	螺钉SM11/64"×40	screw	3

17. 润滑部件/LUBRICATION ASSEMBLY

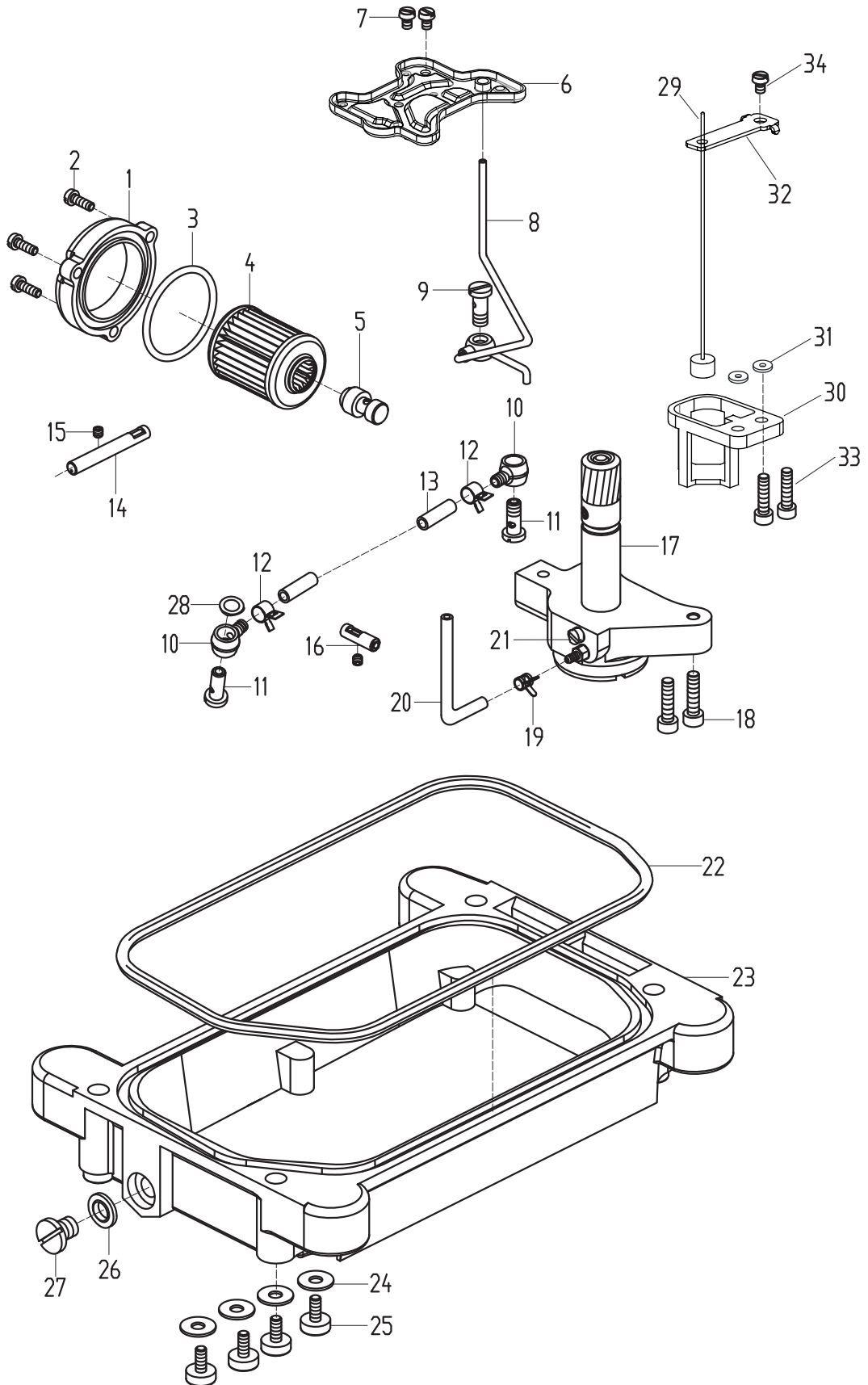

17. 润滑部件/LUBRICATION ASSEMBLY

序号 No.	件号 Parts No.	名称	Description	数量 QT.
1	20008187	滤油器盖	cover of oil distributor	1
2	10009037	螺钉M4×12	screw	3
3	10026756	O型圈	o ring	1
4	10043169	滤油器	oil filter	1
5	10026644	螺钉接头	joint part	1
6	10064522	分油板	plate for guiding oil	1
7	10010554	螺钉M4×5.5	screw	1
8	10057494	配油器组件	oil filter assembly	1
9	10010976	螺钉SM1/4"×40	screw	2
10	10009588	塑料接头	plastic joint	2
11	10009592	螺钉接头	joint part	2
12	10011471	进油短油管夹	fastening ring	1
13	10007796	油管φ4×φ6	oil pipe	1
14	20021641	针杆给油销组件	pin assembly for giving oil	1
15	10009074	螺钉M4×4	screw	2
16	20000790	给油销组件	oil pin assembly	1
17	10026648	油泵组件	oil pump assembly	1
18	10009103	螺钉M4×16	screw	2
19	10009496	4.7油管夹	fastening ring	1
20	10007800	φ3×φ5油管	oil pipe	1
21	10042396	螺钉	screw	2
22	10052381	油盘垫	rubber ring for oil tray	1
23	10052380	油盘	oil tray	1
24	10009447	5垫圈	washer	4
25	10009095	M5×12螺钉	screw	4
26	10009263	垫圈组件	washer assembly	1
27	10009264	螺钉SM3/8"×28	screw	1
28	10012086	垫圈	washer	1
29	10062487	油标	oil leveler	1
30	10009775	油标座	oil leveler block	1
31	10009537	垫圈4.3×13.4×2	washer	2
32	10062477	油标上定位板	oil leveler up locating plate	1
33	10012710	螺钉N4×14	screw	2
34	10009104	螺钉M4×9.5	screw	1

18. H • R装置/H • R DEVICE

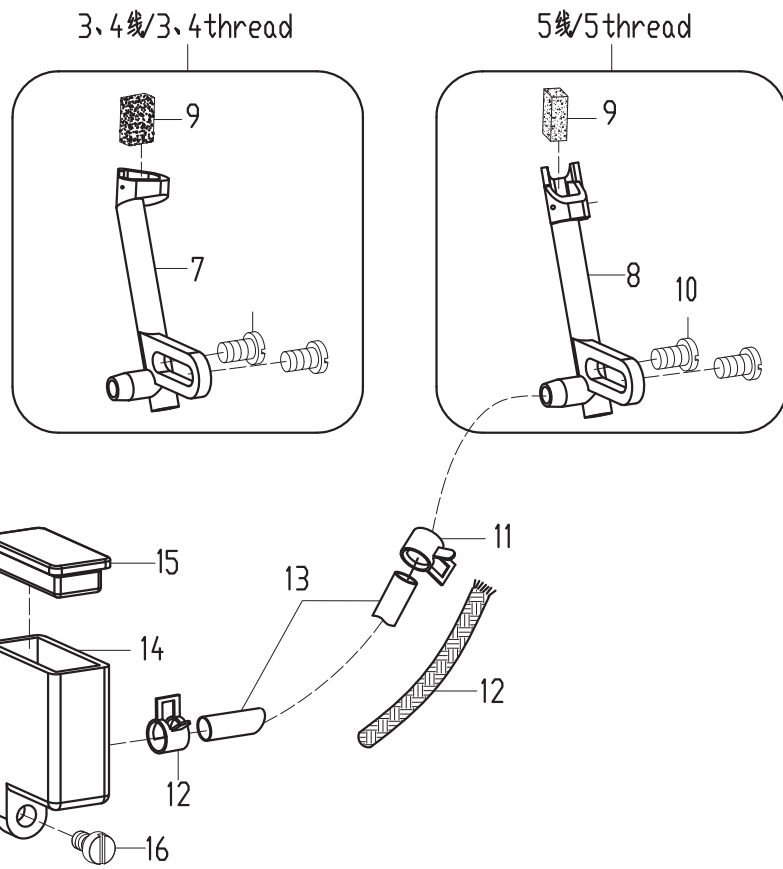
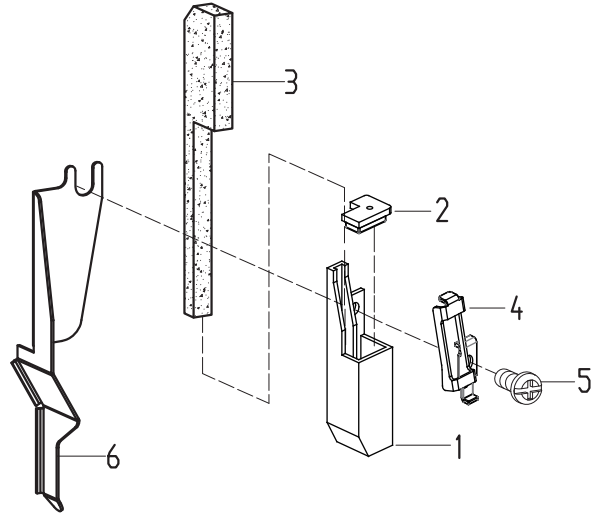

18. H · R装置/H · R DEVICE

序号 No.	件号 Parts No.	名称	Description	数量 QT.
1	10009094	上硅油盒	upper silicon oil box	1
2	10008925	盒盖	box cover	1
3	10008924	毛毡	felt	1
4	10008923	毛毡压板	presser plate for felt	1
5	10009104	螺钉M4×9.5	screw	1
6	10008884	挡油板	plate retaining oil	1
7	10010983	冷却油毡支架 (3、4线)	stand	1
8	10012359	冷却油毡支架 (5线)	stand	1
9	10010982	冷却油毡	felt	1
10	10010074	螺钉SM11/64"×40	screw	2
11	10011471	油管箍	spring ring	1
12	10008072	φ2油线	oil wick	1
13	10007796	油管 φ4×φ6	oil pipe	1
14	10010979	下硅油盒	lower silicon oil box	1
15	10010980	下硅油盒盖	box cover	1
16	10010595	螺钉M4×7.5	screw	1

19. 油盘托架/OIL TANK BRACKET

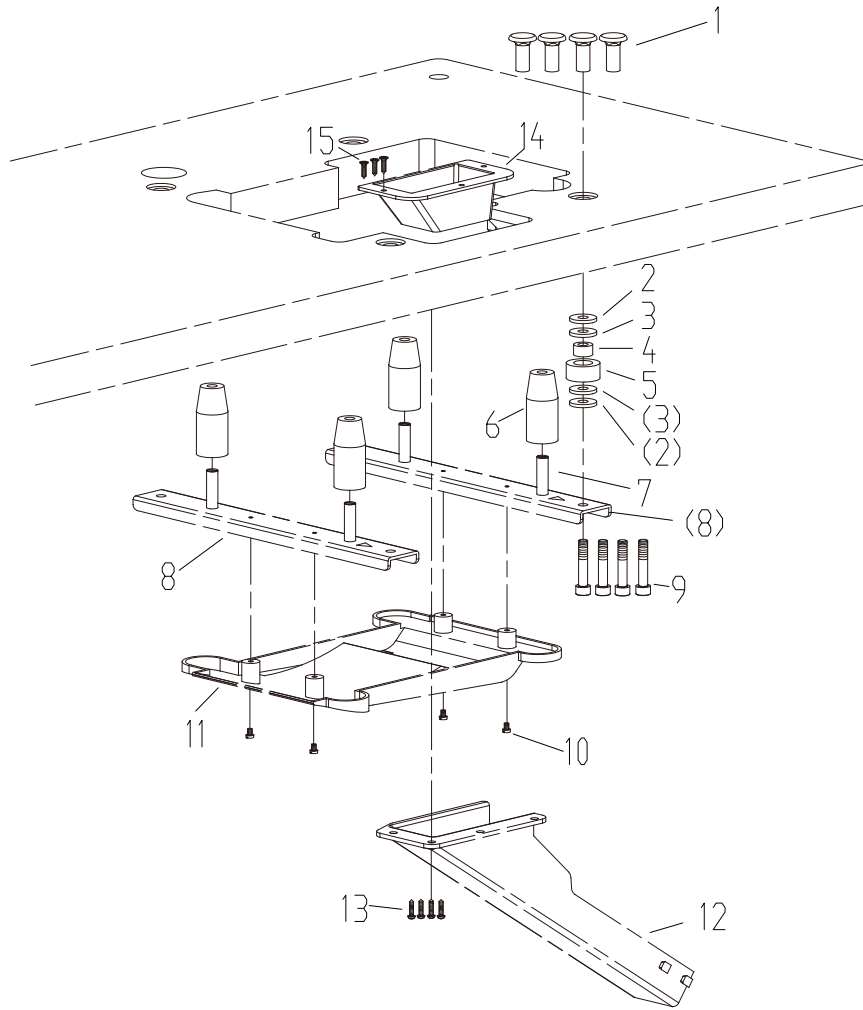

19. 油盘托架/OIL TANK BRACKET

序号 No.	件号 Parts No.	名称	Description	数量 QT.
1	10009596	螺套	bush with inner thread	4
2	10059968	塑料垫	plastic mattress	8
3	10009272	垫圈	washer	8
4	10059967	橡胶垫钢圈	rubber cushion steel ring	4
5	10059966	橡胶垫	rubber blanket	4
6	10059964	托盘橡胶垫	pallet rubber mat	4
7	10059965	支柱	brace	4
8	10059963	托盘支架	the tray support	2
9	10003106	螺钉	screw	4
10	10002924	螺钉	screw	4
11	10059962	托盘	tray	1
12	10033825	下料槽包装组件	the manger packing assembly	1
13	10004981	螺钉	screw	4
14	10033756	下料口	feed opening	1
15	10051357	螺钉	screw	3

